

HOIST RINGS



Safety Engineer..... 134-137

Stainless Safety Engineer136

Safety Engineer –Kits137

Bushing, Washer, Screw Kits138

Tuff Forged™ Side Pull139

Tuff Forged™ Swivel140

Side Load141

Forged.....142

Large Opening Swivel & Pivot143

Pivot Lifting Plates144

Round Base Swivel & Pivot145

Street Plate Lifting Rings..... 146-147

Street Plate Nut.....147

Super Forged Eyebolt148

Alloy Steel Forged Rings148

Lifting Rings149

Safety Precautions 150-156

Newman Tools Inc.
 185 Iber Rd.
 Ottawa, Ontario, Canada K2S 1E7
 Tel 613-836-6776 Fax 613-836-9070

Safety Engineered Hoist Rings

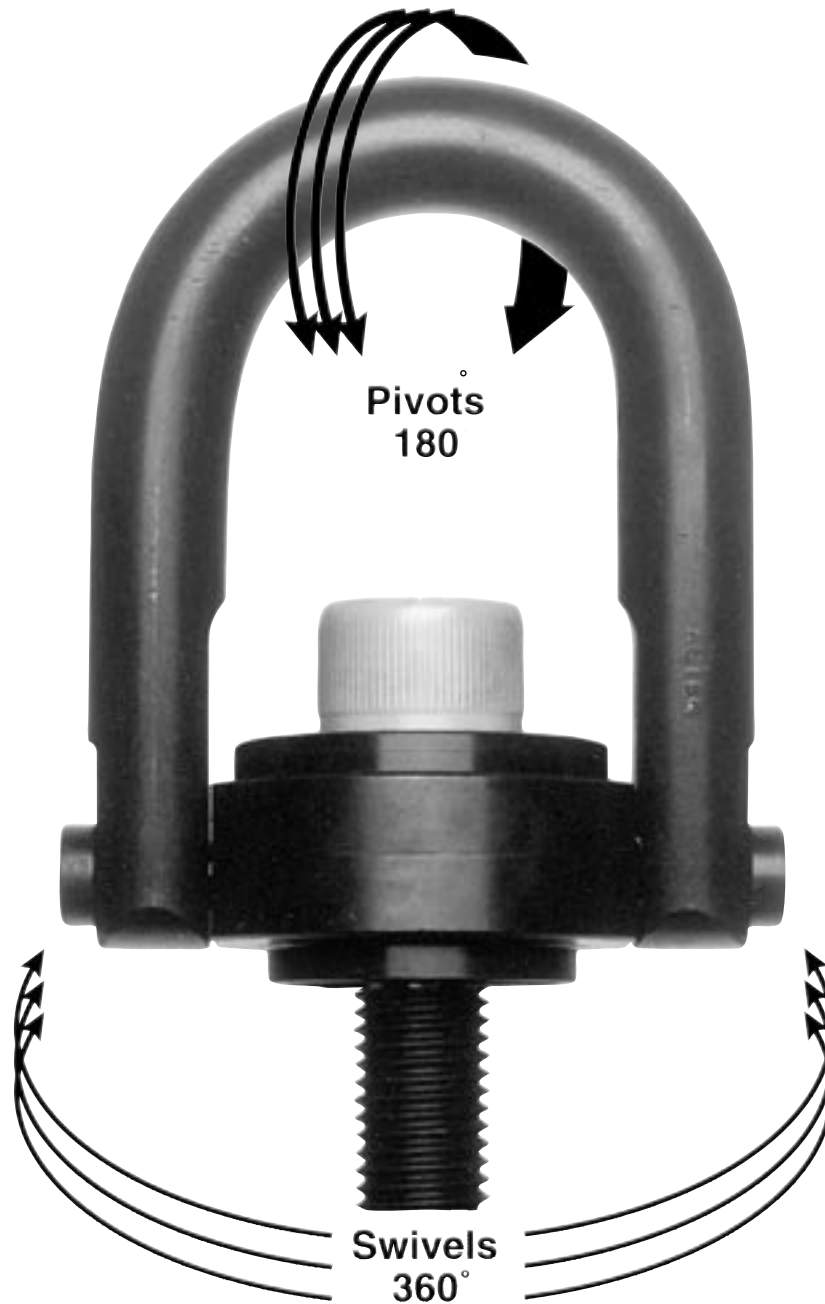

RATED LOAD from 400 lbs. to 125 tons

Safety Engineered Hoist Rings

- Material: AISI 4140 Aircraft Quality
- Finish: Black Oxide Per Mil Spec. (Cadmium plated available)
- Safety Factor: 5:1
- Certified heat treatment
- 100% magnetic particle inspected
- 200% Proof-load Tested, with serial number for traceability

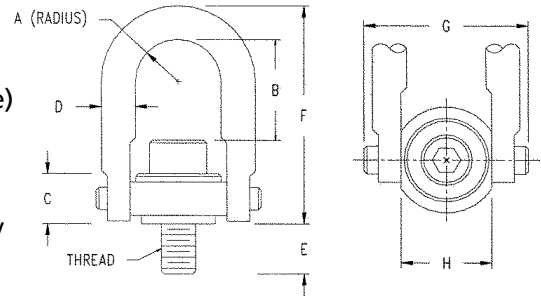

Inch

Rated Load (lbs.)	Thread Size					Standard U-Bar			Long U-Bar				Torque (Ft/lbs)	Wt. (lbs)	
		A	C	D	E	Part No.	B	F	Part No.	B	F	G			H
600	1/4-20	0.43	0.71	3/8	0.54	AK46100	1.27	2.67	-	-	-	1.84	1.00	6	0.3
800	5/16-18	0.43	0.71	3/8	0.29	AK46102	1.27	2.67	-	-	-	1.84	1.00	7	0.3
800	5/16-18	0.43	0.71	3/8	0.54	AK46104	1.27	2.67	-	-	-	1.84	1.00	7	0.3
1,000	3/8-16	0.43	0.71	3/8	0.54	AK46106	1.27	2.67	-	-	-	1.84	1.00	12	0.3
2,000	7/16-14	0.70	0.93	1/2	1.07	AK46606	1.90	3.77	-	-	-	2.58	1.49	22	1.0
2,500	1/2-13	0.70	0.93	1/2	1.07	AK46602	1.84	3.77	-	-	-	2.58	1.49	28	1.0
2,000	7/16-14	0.88	1.22	3/4	0.78	AK46000	2.37	4.78	AK46638	4.34	6.72	3.52	1.99	22	2.6
2,500	1/2-13	0.88	1.22	3/4	0.78	AK46008	2.31	4.78	AK46644	4.25	6.72	3.52	1.99	28	2.6
2,500	1/2-13	0.88	1.22	3/4	1.03	AK46010	2.31	4.78	AK46646	4.25	6.72	3.52	1.99	28	2.6
2,500	1/2-13	0.88	1.22	3/4	1.28	AK46012	2.31	4.78	AK46648	4.25	6.72	3.52	1.99	28	2.6
4,000	5/8-11	0.88	1.22	3/4	0.78	AK46002	2.18	4.78	-	-	-	3.52	1.99	60	2.6
4,000	5/8-11	0.88	1.22	3/4	1.03	AK46004	2.18	4.78	AK46640	4.12	6.72	3.52	1.99	60	2.6
4,000	5/8-11	0.88	1.22	3/4	1.28	AK46006	2.18	4.78	AK46642	4.12	6.72	3.52	1.99	60	2.6
5,000	3/4-10	0.88	1.22	3/4	1.03	AK46014	2.06	4.78	AK46650	4.00	6.72	3.52	1.99	100	3.0
5,000	3/4-10	0.88	1.22	3/4	1.53	AK46018	2.06	4.78	AK46654	4.00	6.72	3.52	1.99	100	3.0
7,000	3/4-10	1.40	1.71	1	1.04	AK46204	3.06	6.52	AK46658	4.65	8.11	5.14	3.00	100	7.0
7,000	3/4-10	1.40	1.71	1	1.54	AK46206	3.06	6.52	AK46660	4.65	8.11	5.14	3.00	100	7.0
8,000	7/8-9	1.40	1.71	1	1.04	AK46202	2.93	6.52	AK46656	4.52	8.11	5.14	3.00	160	7.0
8,000	7/8-9	1.40	1.71	1	1.29	AK46203	2.93	6.52	AK46652	4.52	8.11	5.14	3.00	160	7.0
10,000	1-8	1.40	1.71	1	1.29	AK46210	2.81	6.52	AK46662	4.40	8.11	5.14	3.00	230	7.5
10,000	1-8	1.40	1.71	1	1.54	AK46212	2.81	6.52	AK46664	4.40	8.11	5.14	3.00	230	7.5
10,000	1-8	1.40	1.71	1	2.29	AK46214	2.81	6.52	AK46666	4.40	8.11	5.14	3.00	230	7.5
15,000	1-1/4-7	1.75	2.11	1-1/4	1.89	AK46802	4.12	8.73	-	-	-	6.50	3.76	470	14.0
20,000	1-3/8-6	2.00	2.36	1-1/2	2.64	AK46702	5.20	10.59	-	-	-	7.46	4.31	540	22.0
24,000	1-1/2-6	2.25	2.81	1-3/4	2.70	AK46404	6.41	12.47	-	-	-	8.55	4.87	800	34.0
24,000	1-3/4-5	2.25	2.81	1-3/4	2.70	AK46408	6.41	12.47	-	-	-	8.55	4.87	800	34.0
30,000	2-4-1/2	2.25	2.81	1-3/4	2.96	AK46400	5.91	12.47	-	-	-	8.55	4.87	800	36.0
50,000	2-1/2-8	3.00	4.09	2-1/4	4.00	AK47002	8.03	16.87	-	-	-	11.67	6.52	2100	88.0
50,000	2-1/2-4	3.00	4.09	2-1/4	4.00	AK47006	8.03	16.87	-	-	-	11.67	6.52	2100	88.0
75,000	3-4	3.75	5.27	2-3/4	4.20	AK47200	8.48	19.50	-	-	-	14.15	8.10	4300	166.0
100,000	3-1/2-4	4.00	6.06	3-1/4	7.00	AK47402	9.28	22.09	-	-	-	15.90	8.60	5100	265.0
250,000	6-4	6.00	14.00	5	9.00	AK47602	14.00	33.00	-	-	-	25.00	13.00	9900	790.0

Metric

Rated Load (Kgs)	Thread Size					Standard U-Bar			Long U-Bar				Torque (N-M)	Wt. (Kgs)	
		A	C	D	E	Part No.	B	F	Part No.	B	F	G			H
400	M8x1.25	11	18	10	13	AK46912	32	68	-	-	-	47	25	9	0.17
500	M10x1.50	11	18	10	18	AK46916	30	68	-	-	-	47	25	16	0.17
1,050	M12x1.75	22	30	19	19	AK46924	60	121	AK47124	110	171	89	51	37	1.08
1,900	M16x2.00	22	30	19	29	AK46930	56	121	AK47130	106	171	89	51	80	1.12
2,150	M20x2.50	22	30	19	34	AK46936	52	121	AK47136	102	171	89	51	135	1.19
3,000	M20x2.50	36	43	25	32	AK46942	78	166	AK47142	118	206	131	76	135	3.03
4,200	M24x3.00	36	43	25	37	AK46948	74	166	AK47148	114	206	131	76	311	3.10
4,200	M30x3.50	36	43	25	58	-	-	-	AK46950	108	206	131	76	637	3.10
7,000	M30x3.50	45	54	32	42	AK46956	106	222	-	-	-	165	95	637	6.30
7,000	M30x3.50	45	54	32	62	AK46958	106	222	-	-	-	165	95	637	6.40
11,000	M36x4.00	57	71	44	64	AK46966	166	317	-	-	-	217	124	1085	15.50
12,500	M42x4.50	57	71	44	82	AK46968	160	317	-	-	-	217	124	1085	16.00
13,500	M48x5.00	57	71	44	82	AK46970	154	317	-	-	-	217	124	1085	16.80
22,300	M64x6.00	76	103	57	101	AK46972	204	428	-	-	-	296	165	2847	39.00
31,500	M72x6.00	95	133	70	132	AK46988	220	495	-	-	-	359	206	5830	74.00
51,000	M90x6.00	102	153	83	177	AK46990	235	561	-	-	-	404	218	6914	118.00

Stainless Steel Safety Engineered Hoist Rings

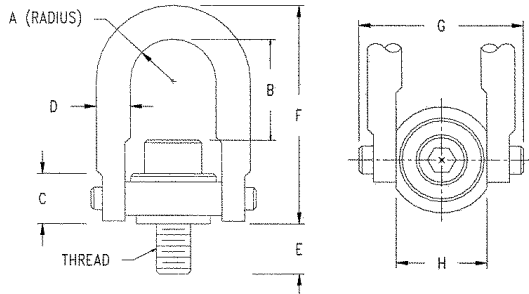

- Designed for lifting, they rotate and pivot to absorb any pitch, roll or sway of unbalanced loads. Will not yield to heavy side loads. Helps prevent the lifting hook from disengaging.
- All loads are especially important from a safety standpoint – provide the kind of safety that protects people and material against accidents.
- For use in outdoor weather and certain chemical and corrosive environments.
- Material: 300 series stainless steel.
- Safety factor: 5:1.
- Liquid penetrant Mil 6868

Inch

Rated Load (lbs.)	Thread Size	A	C	D	E	Standard U-Bar			Long U-Bar				Torque (Ft/lbs)	Wt. (lbs)	
						Part No.	B	F	Part No.	B	F	G			H
400	5/16-18	0.43	0.71	3/8	0.29	AK58102	1.27	2.67	-	-	-	1.84	1.00	3.5	0.3
400	5/16-18	0.43	0.71	3/8	0.54	AK58104	1.27	2.67	-	-	-	1.84	1.00	3.5	0.3
500	3/8-16	0.43	0.71	3/8	0.54	AK58106	1.27	2.67	-	-	-	1.84	1.00	6	0.3
1,250	1/2-13	0.70	0.93	1/2	1.07	AK58602	1.84	3.77	-	-	-	2.58	1.49	14	1.0
1,250	1/2-13	0.88	1.22	3/4	0.78	AK58008	2.31	4.78	AK58644	4.25	6.72	3.52	1.99	14	2.6
1,250	1/2-13	0.88	1.22	3/4	1.03	AK58010	2.31	4.78	AK58646	4.25	6.72	3.52	1.99	14	2.6
1,250	1/2-13	0.88	1.22	3/4	1.28	AK58012	2.31	4.78	AK58648	4.25	6.72	3.52	1.99	14	2.6
2,000	5/8-11	0.88	1.22	3/4	0.78	AK58002	2.18	4.78	-	-	-	3.52	1.99	30	2.6
2,000	5/8-11	0.88	1.22	3/4	1.03	AK58004	2.18	4.78	AK58640	4.12	6.72	3.52	1.99	30	2.6
2,000	5/8-11	0.88	1.22	3/4	1.28	AK58006	2.18	4.78	AK58642	4.12	6.72	3.52	1.99	30	2.6
2,500	3/4-10	0.88	1.22	3/4	1.03	AK58014	2.06	4.78	AK58650	4.00	6.72	3.52	1.99	50	3.0
2,500	3/4-10	0.88	1.22	3/4	1.53	AK58018	2.06	4.78	AK58654	4.00	6.72	3.52	1.99	50	3.0
3,500	3/4-10	1.40	1.71	1	1.04	AK58204	3.06	6.52	AK58658	4.65	8.11	5.14	3.00	50	7.0
3,500	3/4-10	1.40	1.71	1	2.54	AK58206	3.06	6.52	AK58660	4.65	8.11	5.14	3.00	50	7.0
4,000	7/8-9	1.40	1.71	1	1.04	AK58202	2.93	6.52	AK58656	4.52	8.11	5.14	3.00	80	7.0
4,000	7/8-9	1.40	1.71	1	1.29	AK58203	2.93	6.52	AK58652	4.52	8.11	5.14	3.00	80	7.0
5,000	1-8	1.40	1.71	1	1.29	AK58210	2.81	6.52	AK58662	4.40	8.11	5.14	3.00	115	7.5
5,000	1-8	1.40	1.71	1	1.54	AK58212	2.81	6.52	AK58664	4.40	8.11	5.14	3.00	115	7.5
5,000	1-8	1.40	1.71	1	2.29	AK58214	2.81	6.52	AK58666	4.40	8.11	5.14	3.00	115	7.5
7,500	1-1/4-7	1.75	2.11	1-1/4	1.89	AK58802	4.12	8.73	-	-	-	6.50	3.76	235	14.0
12,000	1-1/2-6	2.25	2.81	1-3/4	2.70	AK58404	6.41	12.47	-	-	-	8.55	4.87	400	34.0
15,000	2-4-1/2	2.25	2.81	1-3/4	2.96	AK58400	5.91	12.47	-	-	-	8.55	4.87	400	36.0
25,000	2-1/2-8	3.00	4.09	2-1/4	4.00	AK59002	8.03	16.87	-	-	-	11.67	6.52	1050	88.0
25,000	2-1/2-4	3.00	4.09	2-1/4	4.00	AK59006	8.03	16.87	-	-	-	11.67	6.52	1050	88.0
37,500	3-4	3.75	5.27	2-3/4	4.20	AK59200	8.48	19.50	-	-	-	14.15	8.10	2150	166.0
50,000	3-1/2-4	4.00	6.06	3-1/4	7.00	AK59402	9.28	22.09	-	-	-	15.90	8.60	2550	265.0

Metric

Rated Load (Kgs)	Thread Size	A	C	D	E	Standard U-Bar			Long U-Bar				Torque (N-M)	Wt. (Kgs)	
						Part No.	B	F	Part No.	B	F	G			H
200	M8x1.25	11	18	10	13	AK58912	32	68	-	-	-	47	25	4	0.17
250	M10x1.50	11	18	10	18	AK58916	30	68	-	-	-	47	25	8	0.17
525	M12x1.75	22	30	19	19	AK58924	60	121	AK59124	110	171	89	51	18	1.08
950	M16x2.00	22	30	19	29	AK58930	56	121	AK59130	106	171	89	51	40	1.12
1,075	M20x2.50	22	30	19	34	AK58936	52	121	AK59136	102	171	89	51	68	1.19
1,500	M20x2.50	36	43	25	32	AK58942	78	166	AK59142	118	206	131	76	68	3.03
2,100	M24x3.00	36	43	25	37	AK58948	74	166	AK59148	114	206	131	76	108	3.10
2,100	M30x3.50	36	43	25	58	-	-	-	AK58950	108	206	131	76	108	3.10
3,500	M30x3.50	45	54	32	42	AK58956	106	222	-	-	-	165	95	318	6.30
3,500	M30x3.50	45	54	32	62	AK58958	106	222	-	-	-	165	95	318	6.40
5,500	M36x4.00	57	71	44	64	AK58966	166	317	-	-	-	217	124	542	15.50
6,250	M42x4.50	57	71	44	82	AK58968	160	317	-	-	-	217	124	542	16.00
6,750	M48x5.00	57	71	44	82	AK58970	154	317	-	-	-	217	124	542	16.80
11,150	M64x6.00	76	103	57	101	AK58972	204	428	-	-	-	296	165	1423	39.00
15,750	M72x6.00	95	133	70	132	AK58988	220	495	-	-	-	359	206	2915	74.00
22,300	M90x6.00	102	153	83	177	AK58990	235	561	-	-	-	404	218	3459	118.00

HOIST RINGS

Safety Engineered Hoist Ring Kits

Hoist Rings Kits enable you to custom assemble the precise swivel hoist ring for the job. Kits are available in standard and metric sizes, and come complete with U-Bar (body and sub-assembly), screws, bushings, washers and E-rings – enough to configure over 24 different hoist ring sizes and capacities. A handy accessory kit for lifting and moving heavy loads, and a must for your tool crib.



AK46306 Hoist Ring Kit (Kit includes 4 of each item)

Total Weight 31 lbs.

Sub Assembly	Rated Load (Lbs)	Screw	Screw Size	Thread Length	Bushing	Washer	E-Ring
AK46108 3/8" U-BAR	600	AK46139	1/4-20 x 1-1/4	1/2"	AK46112	AK46120	AK46133
	800	AK46144	5/6-18 x 1-1/4	1/2"	AK46128	AK46126	AK46134
	1,000	AK46146	3/8-16 x 1-1/4	1/2"	AK46152	AK46148	AK46136
AK46600 1/2" U-BAR	2,000	AK46614	7/16-18 x 2	1"	AK46618	AK46616	AK46612
	2,500	AK46636	1/2-13 x 2	1"	AK46628	AK46626	AK46036
AK46020 3/4" U-BAR	4,000	AK46044	5/8-11 x 2-1/4	1"	AK46028	AK46026	AK46034
	5,000	AK46054	3/4-10 x 2-1/4	1"	AK46074	AK46068	AK46038



AK46304 Hoist Ring Kit (Kit includes 4 of each item)

Total Weight 71.5 lbs.

Sub Assembly	Rated Load (Lbs)	Screw	Screw Size	Thread Length	Bushing	Washer	E-Ring
AK46020 3/4" U-BAR	2,500	AK46050	1/2-13 x 2-1/4	1"	AK46072	AK46066	AK46036
	4,000	AK46044	5/8-11 x 2-1/4	1"	AK46028	AK46026	AK46034
	5,000	AK46054	3/4-10 x 2-1/4	1"	AK46074	AK46068	AK46038
AK46220 1" U-BAR	7,000	AK46246	3/4-10 x 3-1/4	1-1/2"	AK46272	AK46266	AK46038
	8,000	AK46242	7/8-9 x 2-3/4	1"	AK46228	AK46226	AK46234
	10,000	AK46250	1-8 x 3	1-1/4"	AK46274	AK46268	AK46238

AK46904 Hoist Ring Kit (Kit includes 4 of each item)

Total Weight 71.5 lbs.

Sub Assembly	Rated Load (Lbs)	Screw	Screw Size	Thread Length	Bushing	Washer	E-Ring
AK46020 3/4" U-BAR	1,050	AK49048	M12 x 1.75 x 50	19	AK49072	AK49066	AK49122
	1,900	AK49056	M16 x 2.00 x 60	29	AK49028	AK49026	AK46034
	2,150	AK49054	M20 x 2.50 x 65	34	AK49074	AK49068	AK46038
AK46220 1" U-BAR	3,000	AK49244	M20 x 2.50 x 75	32	AK49272	AK49266	AK46038
	4,200	AK49250	M24 x 3.00 x 80	37	AK49274	AK49268	AK46228
	4,200	AK49242	M30 x 3.50 x 100	38	AK49228	AK49226	AK46834

Bushing, Washer, Screw Kits

- Aircraft quality "chrome moly" AISI 4140
- Certified heat treatment
- 100% magnetic particle inspected
- Thread sizes available from 1/4" to 2-1/2"
- Change your load rating from 2,500 lbs. to 5,000 lbs. by changing the bushing, washer, and screw



Bushing, Washer Screw Set	Corresponding Hoist Ring	Rated Load (lbs.)	Thread Size	Washer	Bushing	Screw	Screw Size
AK46139-BW	AK46100	600	1/4-20	AK46120	AK46112	AK46139	1/4-20 x .54 x 1-1/4
AK46142-BW	AK46102	800	5/16-18	AK46126	AK46128	AK46142	5/16-18 X .29 X 1
AK46144-BW	AK46104	800	5/16-18	"	"	AK46144	5/16-18 X .54 X 1-1/4
AK46146-BW	AK46106	1,000	3/8-16	AK46148	AK46152	AK46146	3/8-16 X .54 X 1-1/4
AK46614-BW	AK46606	2,000	7/16-14	AK46616	AK46618	AK46614	7/16 X 1.07 X 2
AK46636-BW	AK46602	2,500	1/2-13	AK46626	AK46628	AK46636	1/2-13 X 1.07 X 2
AK46076-BW	AK46000	2,000	7/16-14	AK46064	AK46070	AK46076	7/16-14 X .78 X 2
"	*AK46638	2,000	7/16-14	"	"	"	"
AK46048-BW	AK46008	2,500	1/2-13	AK46066	AK46072	AK46048	1/2-13 X .78 X 2
"	*AK46644	2,500	1/2-13	"	"	"	"
AK46050-BW	AK46010	2,500	1/2-13	"	"	AK46050	1/2-13 X 1.03 X 2-1/4
"	*AK46646	2,500	1/2-13	"	"	"	"
AK46052-BW	AK46012	2,500	1/2-13	"	"	AK46052	1/2-13 X 1.28 X 2-1/2
"	*AK46648	2,500	1/2-13	"	"	"	"
AK46056-BW	AK46002	4,000	5/8-11	AK46026	AK46028	AK46056	5/8-11 X .78 X 2
AK46044-BW	AK46004	4,000	5/8-11	"	"	AK46044	5/8-11 X 1.03 X 2-1/4
"	*AK46640	4,000	5/8-11	"	"	"	"
AK46046-BW	AK46006	4,000	5/8-11	"	"	AK46046	5/8-11 X 1.28 X 2-1/2
"	*AK46642	4,000	5/8-11	"	"	"	"
AK46054-BW	AK46014	5,000	3/4-10	AK46068	AK46074	AK46054	3/4-10 X 1.03 X 2-1/4
"	*AK46650	5,000	3/4-10	"	"	"	"
AK46058-BW	AK46018	5,000	3/4-10	"	"	AK46058	3/4-10 X 1.53 X 2-3/4
"	*AK46654	5,000	3/4-10	"	"	"	"
AK46244-BW	AK46204	7,000	3/4-10	AK46266	AK46272	AK46244	3/4-10 X 1.04 X 2-3/4
"	*AK46658	7,000	3/4-10	"	"	"	"
AK46246-BW	AK46206	7,000	3/4-10	"	"	AK46246	3/4-10 X 1.54 X 3-1/4
"	*AK46660	7,000	3/4-10	"	"	"	"
AK46242-BW	AK46202	8,000	7/8-9	AK46226	AK46228	AK46242	7/8-9 X 1.04 X 2-3/4
"	*AK46656	8,000	7/8-9	"	"	"	"
AK46241-BW	AK46208	8,000	7/8-9	"	"	AK46241	7/8-9 X 1.79 X 3-1/2
AK46250-BW	AK46210	10,000	1-8	AK46268	AK46274	AK46250	1-8 X 1.29 X 3
"	*AK46662	10,000	1-8	"	"	"	"
AK46252-BW	AK46212	10,000	1-8	"	"	AK46252	1-8 X 1.54 X 3-1/4
"	*AK46664	10,000	1-8	"	"	"	"
AK46254-BW	AK46214	10,000	1-8	"	"	AK46254	1-8 X 2.29 X 4
"	*AK46666	10,000	1-8	"	"	"	"
AK46842-BW	AK46802	15,000	1-1/4-7	AK46826	AK46828	AK46842	1-1/4-7 X 1.89 X 4
AK46444-BW	AK46404	24,000	1-1/2-6	AK46426	AK46428	AK46444	1-1/2-6 X 2.70 X 5-1/2
AK46450-BW	AK46400	30,000	2-4-1/2	AK46526	AK46528	AK46450	2-4-1/2 X 2.96 X 5-3/4
AK47052-BW	AK47002	50,000	2-1/2-8	AK47026	AK47028	AK47052	2-1/2-8 X 4 X 8
AK47056-BW	AK47006	50,000	2-1/2-4	"	"	AK47056	"
AK47252-BW	AK47200	75,000	3-4	AK47226	AK47228	AK47252	3-4 X 5.25 X 10-1/2

* Long Bar

HOIST RINGS

Tuff Forged™ Side Pull Hoist Ring Swivels 360 degrees

- Material: Alloy "chrome moly" – strong and tough!
- Finish: Phosphate per DOD-P-16232F
- Safety Factor: 5:1 (*Side pull direction only)
- 100% magnetic particle inspected
- Certified heat treatment
- Rated loads from 1,000 lbs. to 5,000 lbs.
- Ideal for side-mounting applications

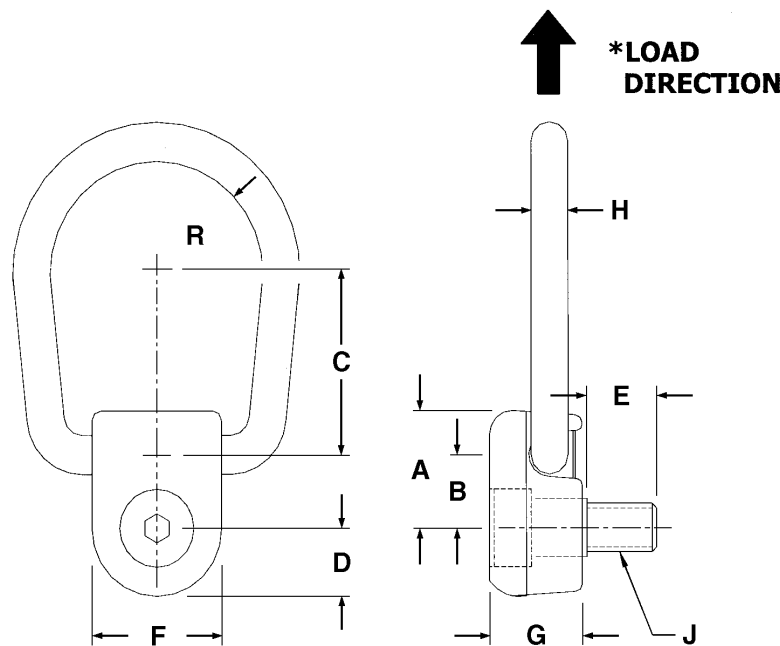

Part No.	Rated Load (lbs.)	Thread Size	A	B	C	D	E	F	G	H	J	R	Wt. (lbs.)
AK68210	1,000	3/8-16	1-1/8	5/8	1-1/2	5/8	5/8	1-1/4	7/8	5/16	3/8-16	13/16	.7
AK68220	2,000	1/2-13	1-5/8	7/8	1-7/8	7/8	3/4	1-3/4	1-5/16	7/16	1/2-13	1-1/8	1.7
AK68225	2,500	5/8-11	1-5/8	7/8	1-7/8	7/8	7/8	1-3/4	1-5/16	7/16	5/8-11	1-1/8	1.7
AK68250	5,000	3/4-10	2-3/16	1-1/8	2-3/4	1	1	2	1-11/16	5/8	3/4-10	1-3/8	3.5
AK68310	1,000	M10x1.50	1-1/8	5/8	1-1/2	5/8	0.6	1-1/4	7/8	5/16	M10x1.50	13/16	.7
AK68320	2,000	M12x1.75	1-5/8	7/8	1-7/8	7/8	0.7	1-3/4	1-5/16	7/16	M12x1.75	1-1/8	1.7
AK68325	2,500	M16x2.00	1-5/8	7/8	1-7/8	7/8	0.8	1-3/4	1-5/16	7/16	M16x2.00	1-1/8	1.7
AK68350	5,000	M20x2.50	2-3/16	1-1/8	2-3/4	1	1	2	1-11/16	5/8	M20x2.50	1-3/8	3.5

Tuff Forged™ Swivel Hoist Rings Swivels 360 degrees – Pivots 180 degrees

- Material: Alloy Certified Aircraft Quality
- Safety Factor: 5:1
- Finish: Phosphate per DOD-P-16232F (Cadmium plated available)
- Certified heat treatment
- 100% magnetic particle inspected
- Capacity: 600-24,000 lbs.
- 200% Proof-load tested, with serial number for traceability

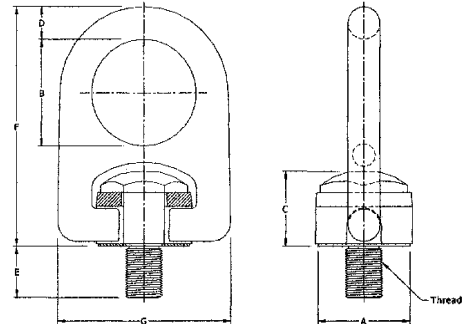

Inch

Part No.	Rated Load (lbs.)	Thread Size	A	B	C	D	E	F	G	Torque (Ft/lbs)	Wt. (lbs.)
AK56100	600	1/4-20	1.23	1.40	1.16	0.44	0.50	3.29	2.38	5	1.0
AK56102	800	5/16-18	1.23	1.40	1.16	0.44	0.50	3.29	2.38	7	1.0
AK56104	800	5/16-18	1.23	1.40	1.16	0.44	1.00	3.29	2.39	7	1.0
AK56106	1,000	3/8-16	1.23	1.40	1.16	0.44	0.50	3.29	2.38	12	1.0
AK56107	1,000	3/8-16	1.23	1.40	1.16	0.44	1.00	3.29	2.38	12	1.0
AK56008	2,500	1/2-13	2.10	2.40	1.97	0.75	0.75	5.60	4.05	28	4.0
AK56010	2,500	1/2-13	2.10	2.40	1.97	0.75	1.00	5.60	4.05	28	4.0
AK56012	2,500	1/2-13	2.10	2.40	1.97	0.75	1.25	5.60	4.05	28	4.0
AK56002	4,000	5/8-11	2.10	2.40	1.97	0.75	0.75	5.60	4.05	60	4.0
AK56004	4,000	5/8-11	2.10	2.40	1.97	0.75	1.00	5.60	4.05	60	4.0
AK56006	4,000	5/8-11	2.10	2.40	1.97	0.75	1.25	5.60	4.05	60	4.0
AK56014	5,000	3/4-10	2.10	2.40	1.97	0.75	1.00	5.60	4.05	100	4.0
AK56018	5,000	3/4-10	2.10	2.40	1.97	0.75	1.50	5.60	4.05	100	4.0
AK56024	7,000	3/4-10	2.80	3.20	2.62	1.00	1.00	7.48	5.40	100	9.0
AK56203	7,000	3/4-10	2.80	3.20	2.62	1.00	1.25	7.48	5.40	100	9.0
AK56206	7,000	3/4-10	2.80	3.20	2.62	1.00	1.50	7.48	5.40	100	9.0
AK56202	8,000	7/8-9	2.80	3.20	2.62	1.00	1.00	7.48	5.40	160	9.0
AK56205	8,000	7/8-9	2.80	3.20	2.62	1.00	1.25	7.48	5.40	160	9.0
AK56210	10,000	1-8	2.80	3.20	2.62	1.00	1.25	7.48	5.40	230	9.0
AK56212	10,000	1-8	2.80	3.20	2.62	1.00	1.50	7.48	5.40	230	9.0
AK56214	10,000	1-8	2.80	3.20	2.62	1.00	2.25	9.35	5.40	230	9.0
AK56802	15,000	1-1/4-7	3.50	4.00	3.28	1.25	2.00	9.35	6.75	470	18.0
AK56804	15,000	1-1/4-7	3.50	4.00	3.28	1.25	2.75	9.35	6.75	470	18.0
AK56702	20,000	1-3/8-6	3.50	4.00	3.28	1.25	2.75	9.35	6.75	540	19.0
AK56404	24,000	1-1/2-6	3.50	4.00	3.28	1.25	2.75	9.35	6.75	800	19.0



Metric

Part No.	Rated Load (Kgs.)	Thread Size	A	B	C	D	(mm) E	F	G	Torque (Kgm)	Wt. (lbs.)
AK56912	400	M8x1.25	1.23	1.40	1.16	0.44	15	3.29	2.38	9	1.0
AK56914	400	M8x1.25	1.23	1.40	1.16	0.44	20	3.29	2.38	9	1.0
AK56916	500	M10x1.50	1.23	1.40	1.16	0.44	15	3.29	2.39	16	1.0
AK56918	500	M10x1.50	1.23	1.40	1.16	0.44	25	3.29	2.38	16	1.0
AK56924	1,050	M12x1.75	2.10	2.40	1.97	0.75	25	5.60	4.05	37	4.0
AK56926	1,050	M12x1.75	2.10	2.40	1.97	0.75	35	5.60	4.05	37	4.0
AK56930	1,900	M16x2.00	2.10	2.40	1.97	0.75	25	5.60	4.05	80	4.0
AK56932	1,900	M16x2.00	2.10	2.40	1.97	0.75	35	5.60	4.05	80	4.0
AK56936	2,150	M20x2.50	2.10	2.40	1.97	0.75	25	5.60	4.05	135	4.0
AK56938	2,150	M20x2.50	2.10	2.40	1.97	0.75	40	5.60	4.05	135	4.0
AK56942	3,000	M20x2.50	2.80	3.20	2.62	1.00	30	7.48	5.40	135	9.0
AK56946	4,200	M24x3.00	2.80	3.20	2.62	1.00	30	7.48	5.40	311	9.0
AK56948	4,200	M24x3.00	2.80	3.20	2.62	1.00	40	7.48	5.40	311	9.0
AK56949	4,200	M30x3.50	2.80	3.20	2.62	1.00	40	7.48	5.40	637	9.0
AK56950	4,200	M30x3.50	2.80	3.20	2.62	1.00	50	7.48	5.40	637	9.0
AK56956	7,000	M30x3.50	3.50	4.00	3.28	1.25	50	9.35	6.75	637	19.0
AK56960	7,000	M33x3.50	3.50	4.00	3.28	1.25	55	9.35	6.75	637	19.0
AK56966	11,000	M36x4.00	3.50	4.00	3.28	1.25	65	9.35	6.75	1085	20.0
AK56968	12,500	M42x4.50	3.50	4.00	3.28	1.25	85	9.35	6.75	1085	21.0

Side Load Hoist Rings Swivels 360 degrees – Pivots 180 degrees

- Material: Aircraft Quality Alloy
- Finish: Black Oxide Per Mil Spec. (Cadmium Plated Available)
- Safety Factor: 5:1
- Certified heat treatment
- 100% magnetic particle inspected
- Designed for side-mounted applications
- Smooth swiveling and pivoting action
- Extra large rings accept many styles and sizes of hoist hooks
- Ideal for stamping and injection mold industries
- Rated loads from 650 lbs. to 29,000 lbs.
- Thread size from 5/16" to 2"

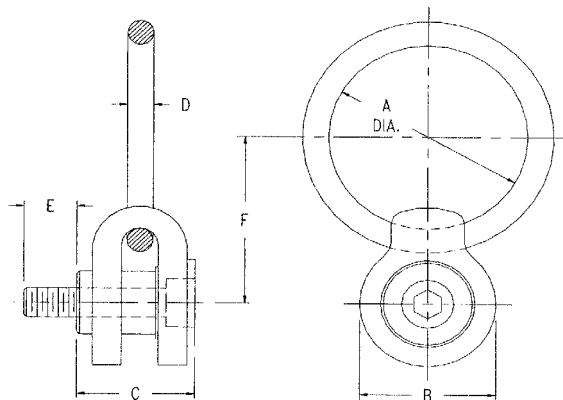

Inch

Part No.	Rated Load (lbs.)	Thread Size	A	B	C	D	E	F	G	Torque (Ft/lbs)	Wt. (lbs.)
AK43510	650	5/16-18	2	1-1/2	1-7/16	3/8	5/8	1-15/16	3/8	3.5	.5
AK43515	800	3/8-16	2	1-1/2	1-7/16	3/8	3/4	1-15/16	3/8	4.5	.5
AK43520	1,800	1/2-13	3	2-3/8	2-1/4	5/8	1	3	1/2	15	3.5
AK43525	2,500	5/8-11	3	2-3/8	2-1/4	5/8	1-1/4	3	1/2	25	3.5
AK43530	4,000	3/4-10	4	3-3/4	3-3/8	1	1-1/2	4-1/2	3/4	50	11.5
AK43535	5,500	7/8-9	4	3-3/4	3-3/8	1	2	4-1/2	3/4	80	11.5
AK43540	7,000	1-8	4	3-3/4	3-3/8	1	2	4-1/2	3/4	90	11.5
AK43545	14,000	1-1/4-7	6	4-5/8	4-5/8	1-3/8	2	6-1/4	1	150	28.0
AK43550	17,000	1-1/2-6	6	4-5/8	4-5/8	1-3/8	2-1/2	6-1/4	1	250	31.5
AK43555	29,000	2-4-1/2	5-1/4x10-1/2	4-5/8	6-5/8	1-1/2	3-1/8	11-1/8	1	300	42.0

Metric

Part No.	Rated Load (Kgs)	Thread Size	A	B	C	D	E	F	G	Torque (Ft/lbs)	Wt. (lbs)
AK43560	325	M8x1.25	2	1-1/2	1-7/16	3/8	16	1-15/16	3/8	3.5	.5
AK43565	500	M10x1.50	2	1-1/2	1-7/16	3/8	20	1-15/16	3/8	4.5	.5
AK43570	725	M12x1.75	3	2-3/8	2-1/4	5/8	24	3	1/2	15	3.5
AK43575	1,400	M16x2.00	3	2-3/8	2-1/4	5/8	31	3	1/2	25	3.5
AK43580	2,290	M20x2.50	4	3-3/4	3-3/8	1	40	4-1/2	3/4	50	11.5
AK43585	3,050	M24x3.00	4	3-3/4	3-3/8	1	47	4-1/2	3/4	80	11.5
AK43590	4,850	M30x3.50	6	4-5/8	4-5/8	1-3/8	44	6-1/4	1	150	28

HOIST RINGS

Forged Hoist Rings

- Pivots a full 180 degrees, but do not rotate. To obtain maximum load capacity, high strength socket head cap screw must be used.
- Material: Aircraft Quality Alloy "chrome moly" – strong and tough!
- Finish: Black Oxide Per Mil Spec.
- Safety Factor: 6:1
- Certified heat treatment
- 100% magnetic particle inspected
- Fixed mounting plate holds ring secure to prevent rotation
- Rated loads from 2,000 to 20,000 lbs.
- Great for anchor or tiedown applications
- Ideal for lifting boxes or containers

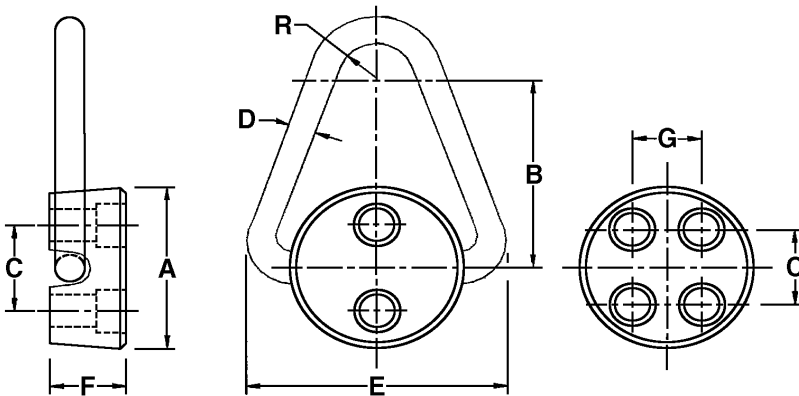
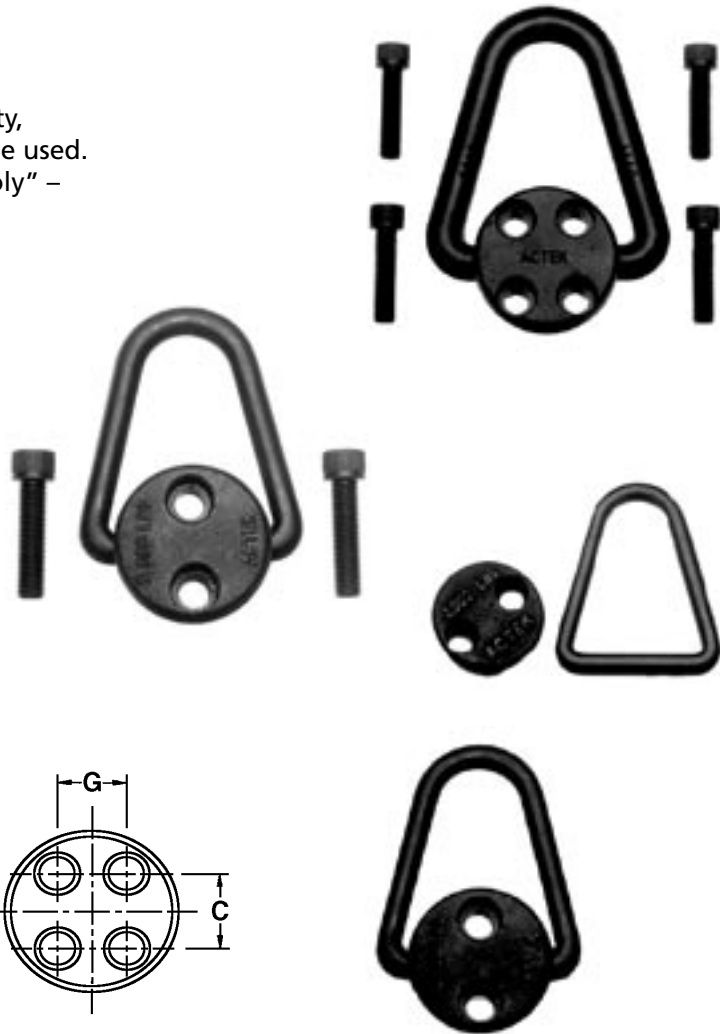

Hoist Ring Part No.	Rated Load (lbs)	Dia. A	B	C	D	E	F	G	R	Torque (Ft/lbs)	Wt. (lbs.)
AK68060	2,000	1-3/4	2	1	5/16	2-1/2	3/4	–	1/2	4-7	.75
AK68070	2,500	2-1/4	2-1/2	1-1/8	3/8	3-3/16	7/8	–	5/8	7-10	1.25
AK68080	5,000	2-5/8	3	1-1/2	1/2	3-7/8	1-1/8	–	3/4	20-25	2.00
AK68090	12,000	3-1/8	4	1-5/8	3/4	5-1/8	1-3/8	1-1/4	7/8	20-25	4.00
AK68100	20,000	3-5/8	5	2-1/16	1	6-3/8	1-7/8	1-1/4	1	30-35	7.50

Hoist Ring Part No.	Standard Screw			Metric Screw			Wt. (lbs.)
	Part No.	Thread Size	Screw Length	Part No.	Thread Size	Screw Length	
AK68060	AK46144	5/16-18	1-1/4	AK49142	M8x1.25	30	.10
AK68070	AK46146	3/8-16	1-1/4	AK49146	M10x1.50	35	.10
AK68080	AK46048	1/2-13	2	AK49048	M12x1.75	50	.20
AK68090	AK46052	1/2-13	2-1/2	AK49048	M12x1.75	50	.20
AK68100	AK46043	5/8-11	3	AK49056	M16x2.00	60	.30

Large Opening Swivel & Pivot Hoist Rings Swivels 360 degrees – Pivots 180 degrees

- Extra large inside diameter allows the user to utilize many styles and larger size hoist hooks.
- Die and mold makers will like the way this ring reacts to laying down and rolling the dies and molds over to work on them.
- Smooth swiveling and pivoting action
- Certified heat treatment
- 100% magnetic particle inspected
- Rated loads from 800 lbs. to 10,000 lbs.
- Material: Aircraft Quality Alloy
- Finish: Black Oxide Per Mil Spec. (Cadmium Plated Available)
- Safety Factor: 4:1

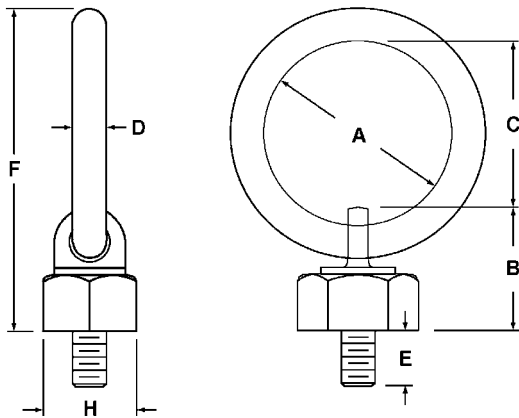

Inch

Part No.	Rated Load (lbs)	A	B	C	D	E	F	H	Thread Size	Wt. (lbs.)
AK42620	800	2	1.48	1.75	3/8	1/2	3.60	1	5/16-18	.7
AK42630	1,000	2	1.48	1.75	3/8	5/8	3.60	1	3/8-16	.7
AK42640	2,500	3	2.68	2.57	5/8	3/4	5.87	1-3/4	1/2-13	3.0
AK42650	4,000	3	2.68	2.57	5/8	1	5.87	1-3/4	5/8-11	3.0
AK42660	7,000	4	4.25	3.31	1	1-1/4	8.56	2-3/4	3/4-10	9.5
AK42670	10,000	4	4.25	3.31	1	1-1/2	8.56	2-3/4	1-8	9.5

Metric

Part No.	Rated Load (Kgs)	A	B	C	D	E	F	H	Thread Size	Wt. (lbs.)
AK42920	400	2	1.48	1.75	3/8	1/2	3.60	1	M8x1.25	.7
AK42930	500	2	1.48	1.75	3/8	5/8	3.60	1	M10x1.50	.7
AK42940	1,050	3	2.68	2.57	5/8	3/4	5.87	1-3/4	M12x1.75	3.0
AK42950	1,900	3	2.68	2.57	5/8	1	5.87	1-3/4	M16x2.00	3.0
AK42960	2,150	4	4.25	3.31	1	1-1/4	8.56	2-3/4	M20x2.50	9.5
AK42970	4,200	4	4.25	3.31	1	1-1/2	8.56	2-3/4	M24x3.00	9.5

Pivot Lifting Plate Pivots 180 degrees

To obtain maximum load capacity, high strength alloy screws must be used.

- Material: Aircraft Quality Alloy
- Finish: Black Oxide Per Mil Spec. (Cadmium Plated Available)
- Safety Factor: 5:1
- Certified heat treatment
- 100% magnetic particle inspected
- Large bail pivots 180°
- Ideal for certain OEM applications
- Rugged tapered plate minimizes shear force on high strength alloy screw
- Base plate can be welded into position, thus eliminating the use of screws
- Use high tensile alloy screw equivalent to Grade 8

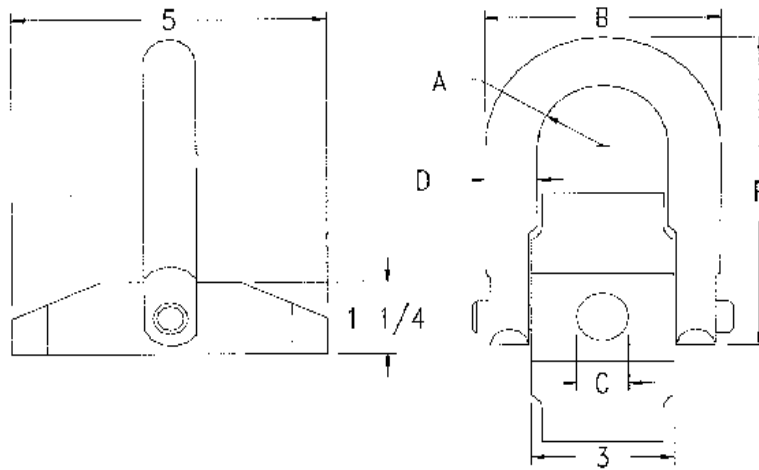

Part No.	Rated Load (lbs)	A	B	C	D	F	Thread Size	Torque Ft/lbs	Wt. (lbs.)
AK44410	7,000	1.40	4-13/16	3/4	1	6-1/2	3/4-10	100	6.8
AK44610	7,000	1.40	4-13/16	3/4	1	8-7/64	3/4-10	100	7.5
AK44415	8,000	1.40	4-13/16	7/8	1	6-1/2	7/8-9	160	6.7
AK44615*	8,000	1.40	4-13/16	7/8	1	8-7/64	7/8-9	160	7.4
AK44420	10,000	1.40	4-13/16	1	1	6-1/2	1-8	230	6.7
AK44620*	10,000	1.40	4-13/16	1	1	8-7/64	1-8	230	7.3

* Long Bar

Round Base Swivel & Pivot Hoist Rings

Swivels 360 degrees – Pivots 180 degrees

To obtain maximum load capacity, high strength alloy screws must be used.

- Material: Aircraft Quality Alloy
- Finish: Black Oxide Per Mil Spec. (Cadmium Plated Available)
- Safety Factor: 5:1
- Certified heat treatment
- 100% magnetic particle inspected
- Direct mounting
- Wide round base helps distribute shear loads
- Rated load capacities from 2,500 lbs. to 20,000 lbs.
- Many OEM applications
- Perfect for pre-cast concrete products: simply cast a threaded anchor or stud into the concrete part. Mount the hoist ring and you have an easy, safe lifting/handling application.



NOTE: Thread engagement should be 1-1/2 times the diameter of the equivalent of Grade 8 alloy screws.

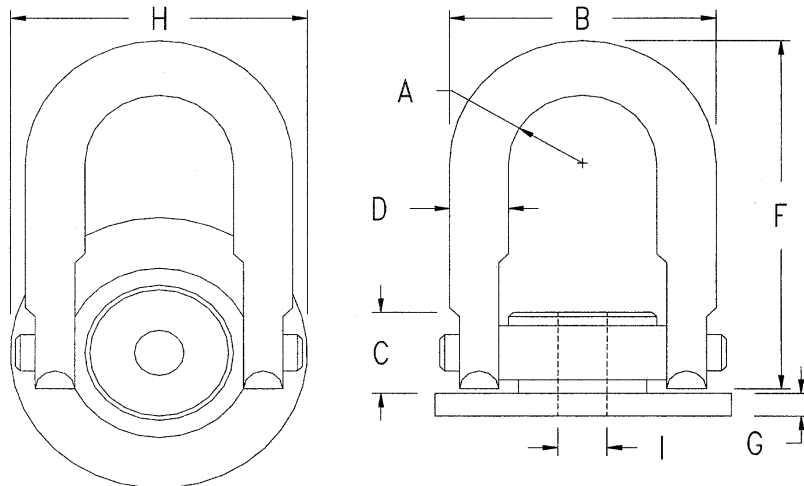

Part No.	Rated Load (lbs)	A	B	C	D	F	G	H	I	Thread Size	Torque Ft/lbs	Wt. (lbs.)
AK44646	2,500	0.88	3-1/4	1-7/64	3/4	6-3/4	1/4	3.5	1/2	1/2-13	28	3.5
AK44642	4,000	0.88	3-1/4	1-7/64	3/4	6-3/4	1/4	3.5	5/8	5/8-11	60	3.5
AK44654	5,000	0.88	3-1/4	1-7/64	3/4	6-3/4	1/4	3.5	3/4	3/4-10	100	3.5
AK44660	7,000	1.40	4-13/16	1-1/2	1	8-7/64	13/32	5.0	3/4	3/4-10	100	9.0
AK44656	8,000	1.40	4-13/16	1-1/2	1	8-7/64	13/32	5.0	7/8	7/8-9	160	9.0
AK44666	10,000	1.40	4-13/16	1-1/2	1	8-7/64	13/32	5.0	1	1-8	230	9.0
AK44802	15,000	1.75	6	1-7/8	1-1/4	8-3/4	1/2	7.0	1-1/4	1-1/4-7	470	17.0
AK44704	20,000	2.00	7-11/32	2	1-1/2	10-3/16	1/2	7.0	1-1/2	1-1/2-6	800	24.0

HOIST RINGS

Street Plate Lifting Ring



PATENT
PENDING



- Steel trench plates are used to cover trenches in streets and roadways in order to facilitate traffic flow during construction or repair.
- Street Plate Lifting Ring lugs are used for tightening and loosening with hammer or steel bar.
- The Street Plate Lifting Ring is used by utility companies, contractors and trench plate rental companies.



Street Plate Lifting Ring Swivels 360 degrees – Pivots 180 degrees

- Material: 4140 Certified Aircraft Quality
- Finish: Black Oxide Per Mil Spec. (Cadmium Plated Available)
- Safety Factor: 5:1
- Certified heat treatment
- 100% magnetic particle inspected

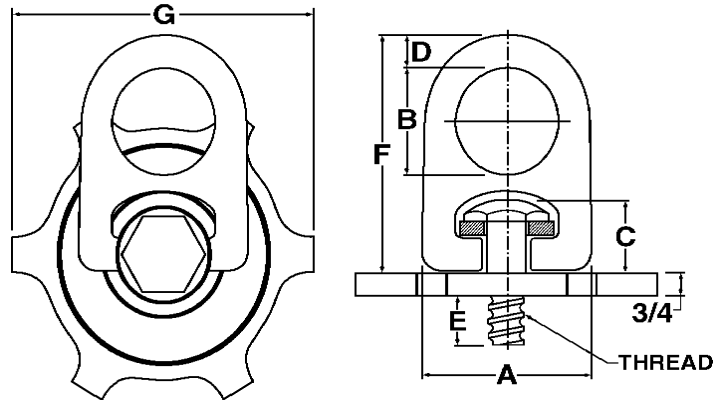

Part No.	Rated Load (lbs.)	A	B	C	D	E	F	G	Thread Size	Torque (Ft/lbs)	Wt. (lbs.)
AK38215	10,000	5.40	3.20	2.62	1	1	7.48	7	Coil	1-1/4	16.0
AK38225	10,000	5.40	3.20	2.62	1	1-1/2	7.48	7	Coil	1-1/2	16.0
AK38235	10,000	5.40	3.20	2.62	1	1	7.48	7	Acme	1-1/4	16.0
AK38245	10,000	5.40	3.20	2.62	1	1-1/2	7.48	7	Acme	1-1/2	16.0
AK38865	15,000	6.75	4	3.28	1-1/4	1	9.35	9	Coil	1-1/4	28.0
AK38875	15,000	6.75	4	3.28	1-1/4	1-1/2	9.35	9	Coil	1-1/2	28.0
AK38885	15,000	6.75	4	3.28	1-1/4	1	9.35	9	Acme	1-1/4	28.0
AK38895	15,000	6.75	4	3.28	1-1/4	1-1/2	9.35	9	Acme	1-1/2	28.0

Street Plate Nut

- Material: Aircraft Quality Alloy
- Certified heat treatment
- 100% magnetic particle inspected
- Welding Rod-Alloy #7018

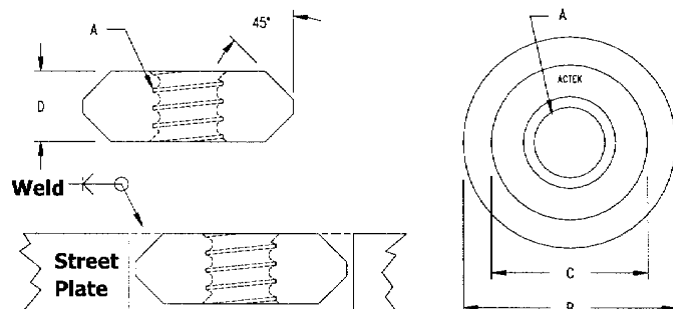

Part No.	Thread Type	Thread Size (A)	B	C	D
AK48801	Coil	1"-3.5	3	2-1/8	3/4
AK48802	Coil	1"-3.5	3	2-1/8	7/8
AK48803	Coil	1"-3.5	3	2-1/8	1
AK48812	Coil	1-1/4"-3.5	3	2-1/8	3/4
AK48815	Coil	1-1/4"-3.5	3	2-1/8	7/8
AK48816	Coil	1-1/4"-3.5	3	2-1/8	1-1/4
AK48817	Coil	1-1/4"-3.5	3	2-1/8	1-1/2
AK48804	Coil	1-1/2"-3.5	3-1/2	2-3/8	1
AK48806	Coil	1-1/2"-3.5	3-1/2	2-3/8	1-1/4
AK48856	Coil	1-1/2"-3.5	3-1/2	2-3/8	1-1/2
AK48820	Acme	1-1/4"-5	3	2-1/8	1
AK48824	Acme	1-1/2"-5	3-1/2	2-3/8	1
AK48823	UNC	1"-8	3	2-1/8	1
AK48826	Coil	1-1/2"-3.5	3-1/2	2-3/8	1-1/2
AK48827	UNC	1-1/2"-6	3-1/2	2-3/8	1-1/2
AK48829	UNC	2-4-1/2	3-1/2	2-3/8	1-1/2

Super Forged Eyebolt

- Aircraft quality "chrome moly"
- Certified heat treatment
- 100% magnetic particle inspected
- Galvanized for outdoor use
- A "rugged" eyebolt that is designed for lifting

Note: Rated Capacity is for STRAIGHT LIFTS – angle lifts should be avoided.



**AVAILABLE IN
UNC AND ACME
THREAD SIZES**

Part No.	Rated Load	Thread Size	Thread Length
AK48650	8,000	1-1/4-3.5 Coil	1.0
AK48660	10,000	1-1/2-3.5 Coil	1.5

Alloy Steel Forged Rings

- Sizes from 3/8 x 2" to 1-1/2 x 6"
- Certified heat treated
- Load ratings from 1,500 lbs. to 31,300 lbs.



Part No.	Working Load Limits(lbs)	Diameter Stock A	Inside Diameter B
AK43122	1,500	3/8	2
AK43022	6,100	5/8	3
AK43322	9,100	3/4	4
AK43222	18,400	1	4
AK43822	23,200	1-3/8	6
AK43422	31,300	1-1/2	6

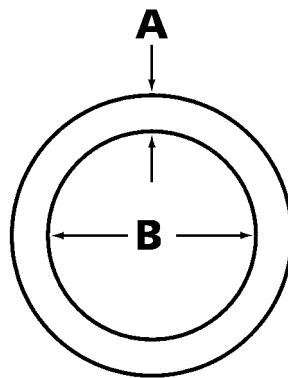

A = Specify size required
B = Specify size required

LIFTING RING

Swivels 360 degrees – Pivots 90 degrees

- Material: Aircraft Quality Alloy
- Finish: Black Oxide Per Mil Spec. (Cadmium Plated Available)
- Designed for side mounting applications
- Great for dies and molds
- Rated load from 650 - 15,000 lbs.
- Safety Factor: 4:1
- Certified heat treatment
- 100% magnetic particle inspected

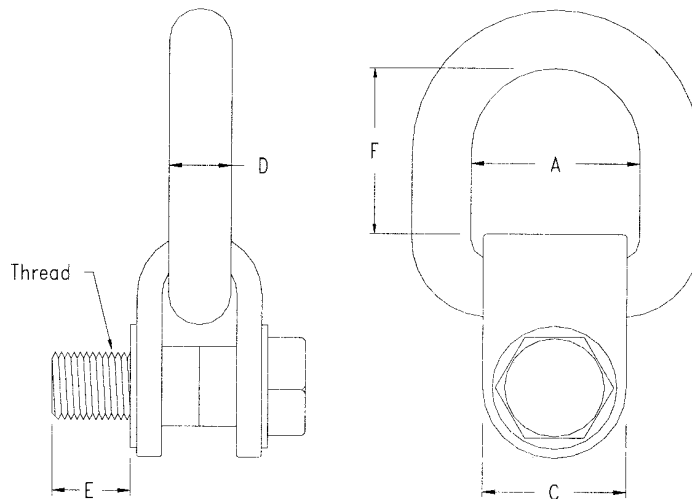

Inch (color coded yellow)

Part No. D-Ring	Part No. Long D-Ring	Rated Load(lbs)	Thread Size	A	C	D	E	D-Ring	F Long D-Ring	Torque (Ft/Lbs)	Wt. (lbs.)
AK43700	-	650	5/16-18	1-7/8	1-1/2	5/8	0.75	2	-	7	1.7
AK43710	AK43711	2,000	1/2-13	1-7/8	1-1/2	5/8	1.25	2.5	3.5	28	2.0
AK43720	AK43721	2,500	5/8-11	1-7/8	1-1/2	5/8	1.25	2.5	3.5	60	2.0
AK43730	AK43731	5,000	3/4-10	2-1/4	2	3/4	2	3	4	100	3.5
AK43740	AK43741	6,500	7/8-9	2-1/4	2	3/4	2	3	4	160	4.0
AK43750	AK43751	7,000	1-8	2-1/4	2	3/4	2	3	4	230	4.0
AK43760	AK43761	12,000	1-1/4-7	3-1/4	3	1-1/8	2.5	4	5.5	470	11.0
AK43770	AK43771	15,000	1-1/2-6	3-1/4	3	1-1/8	3	4	5.5	800	13.0

Metric (color coded blue)

Part No. D-Ring	Part No. Long D-Ring	Rated Load(Kgs)	Thread Size	A	C	D	E	D-Ring	F Long D-Ring	Torque (Kgm)	Wt. (lbs.)
AK43900	-	300	M8x1.25	1-7/8	1-1/2	5/8	25	2	-	0.86	1.7
AK43905	-	400	M10x1.50	1-1/2	1-1/4	5/16	25	2	-	1.5	1.8
AK43910	AK43911	1,000	M12x1.75	1-7/8	1-1/2	5/8	35	2.5	3.5	3.7	2.0
AK43920	AK43921	1,050	M16x2.00	1-7/8	1-1/2	5/8	35	2.5	3.5	8.4	2.0
AK43930	AK43931	2,150	M20x2.50	2-1/4	2	3/4	50	3	4	14	3.5
AK43940	AK43941	3,000	M24x3.00	2-1/4	2	3/4	50	3	4	31	3.7
AK43950	AK43951	5,000	M30x3.50	3-1/4	3	1-1/8	70	4	5.5	60	11.0
AK43960	AK43961	7,000	M36x4.00	3-1/4	3	1-1/8	70	4	5.5	100	13.0

HOIST RINGS

HOIST RING SAFETY INFORMATION

Do's & Don'ts of Installing and Using Hoist Rings

DO:

- **ALWAYS READ SAFETY PRECAUTION PAGE PRIOR TO USE OR INSTALLATION.**
- **ALWAYS INSPECT THE HOIST RING BEFORE EACH USE.**
- Regularly inspect all hoist ring parts.
- Always tighten the screw to the recommended torque value.
- Always make sure that the hoist ring is free to pivot and swivel in all directions.
- Always choose a hoist ring with the proper load rating. See the "Actual Load" equation on page 151 to help you choose the appropriate hoist ring.
- Always make sure that the bushing of the hoist ring sits flush against the object being lifted.
- Install hoist rings in materials that have a tensile strength of at least 80,000 psi.
- Always make sure the thread engagement is at least 1.5 times the diameter of the hoist ring screw.
- When installing a hoist ring in a through-hole with a nut and washer, make sure to use a Grade 8 nut that has full thread engagement.
- Consider periodic load-testing as an extra precaution.

DON'T:

- **NEVER EXCEED RATED LOAD.**
- **NEVER APPLY SHOCK LOAD.**
- Never use a hoist ring that you believe is damaged.
- Never use a hoist ring that has damaged threads on the screw.
- Never use a hoist ring in an application where it does not pivot and swivel in every direction freely.
- Never use a hoist ring that is not tightened to the recommended torque.
- Never replace the components of the hoist ring with anything other than TE-CO recommended parts.
- Never use a hook larger than the diameter of the hoist ring opening.
- Never shim or use washers between the hoist ring and surface of object being lifted.

Hoist Ring Inspection & Maintenance

ALWAYS INSPECT THE HOIST RING BEFORE EACH USE. MAKE SURE THAT:

- **The screw is tightened to the recommended torque.** If the screw is not tightened, the threads may be stripped on a vertical lift.
- **The bushing of the hoist ring sits flush against the object being lifted.** This ensures that the recommended torque puts the proper preload onto the hoist ring, allowing the hoist ring to reach its full 5:1 safety factor.
- **The hoist ring is free to swivel and pivot in every direction.** If the hoist ring binds up in any direction, it should be removed from service.
- **There are no signs of corrosion.** This can cause deterioration to the hoist ring material, allowing for fatigue or cracking to take place. It may also prevent the hoist ring from pivoting and swiveling freely.
- **There are no signs of damage, wear or cracks – especially on the screw, shoulder pins, and bail –** which may be an indication that the hoist ring is coming into contact with something during use. This should be avoided as such contact can cause binding and shock loads which exceed the rating of the hoist ring.
- **The shoulder pins are secure and do not rotate or come loose.** This can be checked by using pliers to rotate the shoulder pins by hand. If the shoulder pin does rotate, it is no longer securely in place and could come loose, causing the hoist ring to break.

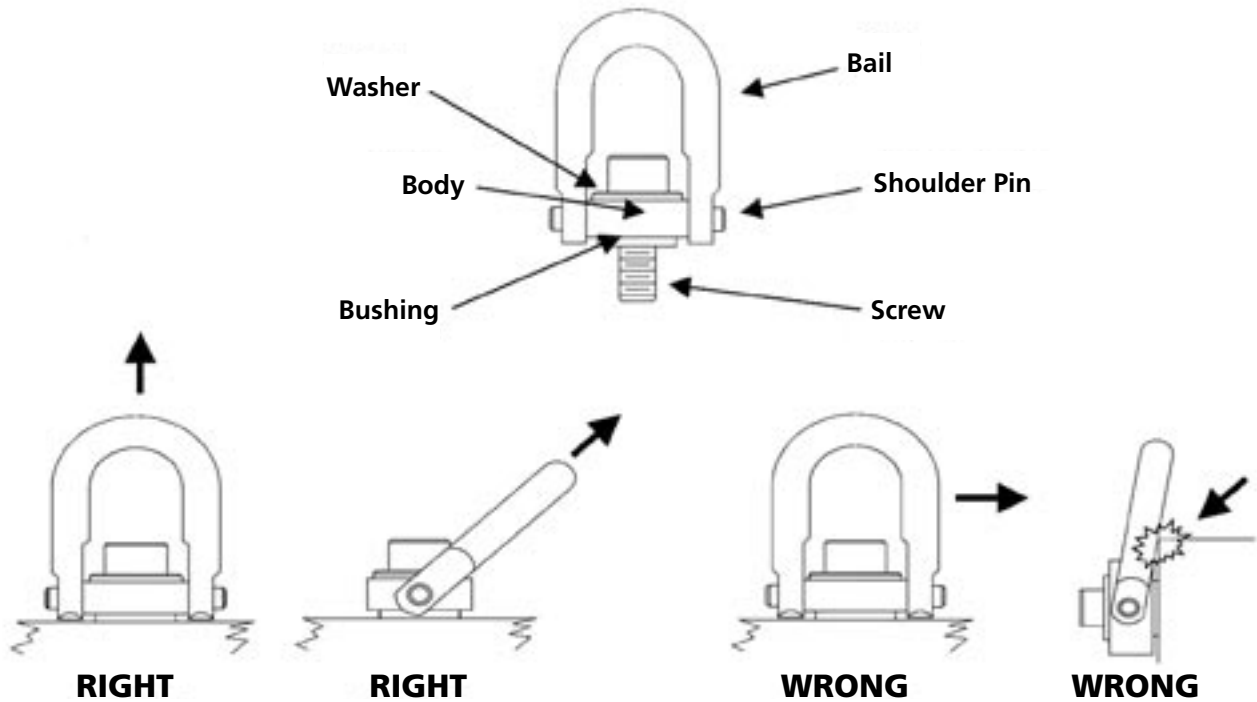

Important: The load on each hoist ring is **not** simply total weight divided by the number of hoist rings. The resultant force can be significantly greater at shallow lift angles and with unevenly distributed loads. See the example and chart below.

L = Load experienced by hoist ring
W = Total weight = 2,000 Lbs.

N = Number of hoist rings = 4
A = Lifting angle

$$L = \frac{W}{N \sin A}$$

If A = 60:
 $L = \frac{2000}{4 \sin 60} = 577 \text{ lbs.}$

If A = 20:
 $L = \frac{2000}{4 \sin 20} = 1,462 \text{ lbs.}$

Lifting Angle (Degrees)	Number of Hoist Rings	Weight of Load (Pounds)	Actual Applied Load on Hoist Ring (Pounds)
90	4	2,000	500
80	4	2,000	510
70	4	2,000	535
60	4	2,000	580
50	4	2,000	655
40	4	2,000	780
30	4	2,000	1,000
20	4	2,000	1,465

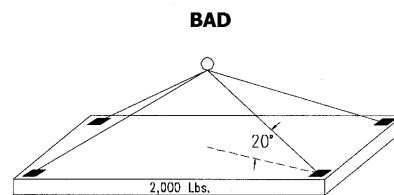
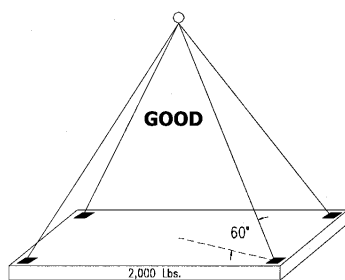

Swivel Hoist Rings vs. Shouldered Eyebolt

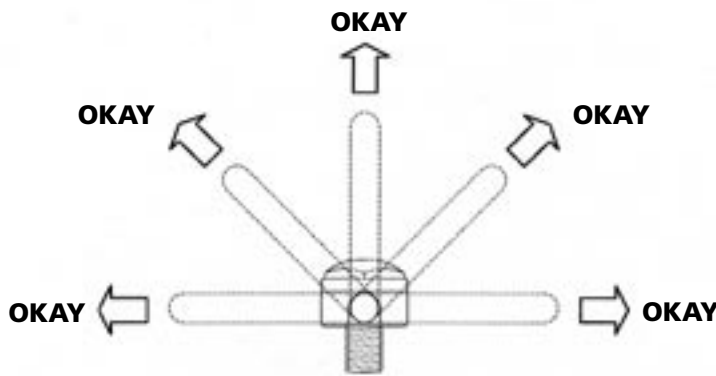

SWIVEL HOIST RING

Same load rating at any angle

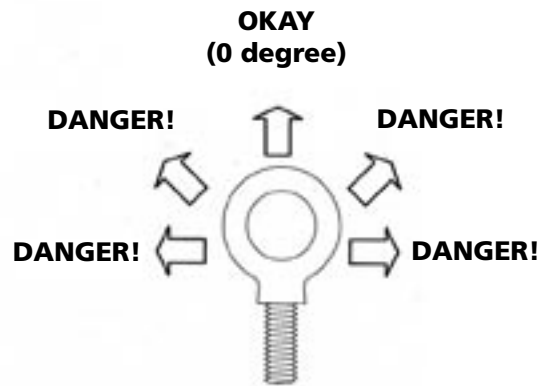

SHOULDERED EYEBOLT

Load rating good only for zero degree

Eyebolts have been used for over 100 years. They do a good job when used **properly** – meaning the **direction of the load must be at zero degree**. If the load shifts or the direction of loading on the eyebolt is as much as 10 degrees off the zero line of force, the result is a bent eyebolt. **When you bend the eyebolt, it is broken!**

You can't see the break most of the time. If you examine the bent area using x-ray, you will find the damage. **Continued use of the eyebolt will lead to failure.**

Swivel Hoist Rings are designed for lifting at any angle because they can swivel 360° and pivot 180°. Therefore, the rated load remains the same regardless of the angle of force. The result is **increased safety and peace of mind.**

Hoist Ring Product Safety Facts

WARNING: PRIOR TO USING ANY HOIST RING, PLEASE READ THE FOLLOWING FOR PROPER INSTALLATION AND USAGE:

- As with all mechanical devices, regular inspection for wear and strict adherence to use instruction is necessary to prevent misuse failure.
- Despite the 5:1 safety factor, **NEVER EXCEED THE RATED LOAD CAPACITY**. This safety margin is necessary in case of misuse, which could drastically lower load capacity.
- Tighten mounting screws to torque recommended. Periodically check torque because screws could loosen in extended service.
- Tensile strength of parent material should be above 80,000 PSI to achieve full load rating. For weaker material, consider through-hole mounting with a nut and washer on the other side.
- **DO NOT APPLY SHOCK LOADS**. Always lift gradually. Repeat magnaflux testing if shock loading occurs.
- **Make sure the hoist ring pivots and rotates freely in all directions.**
- **Rated load will be reduced based on different angles of the loading.**

Important: The load on each hoist ring is not simply total weight divided by the number of hoist rings. The resultant force can be significantly greater at shallow lift angles and with unevenly distributed loads. See the example on the following page.

SAFETY ENGINEERED SWIVEL HOIST RINGS



RIGHT

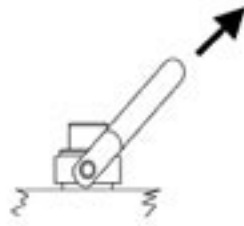

RIGHT

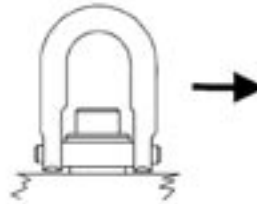

WRONG

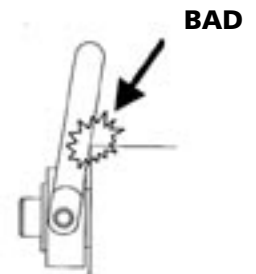

WRONG

FORGED SWIVEL HOIST RINGS



RIGHT



RIGHT

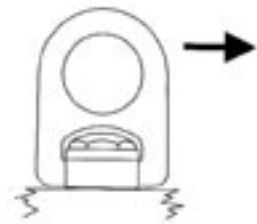

WRONG

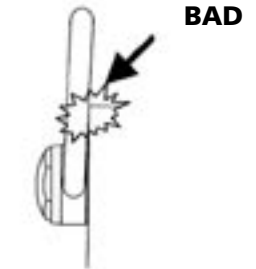

WRONG

STAINLESS STEEL SWIVEL HOIST RINGS

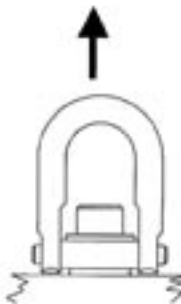

RIGHT

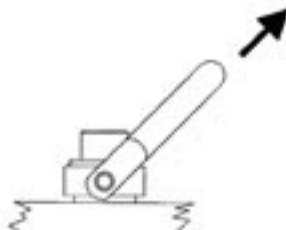

RIGHT

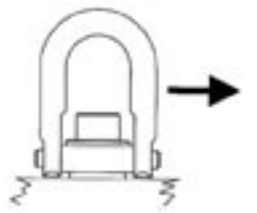

WRONG

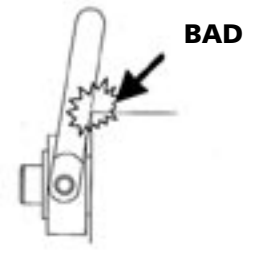

WRONG

SIDE LOAD HOIST RINGS

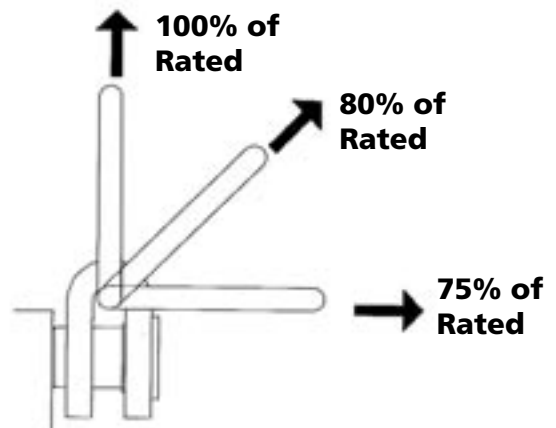
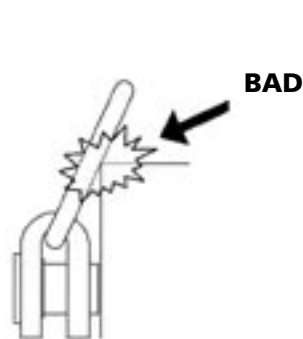

LIFTING RINGS

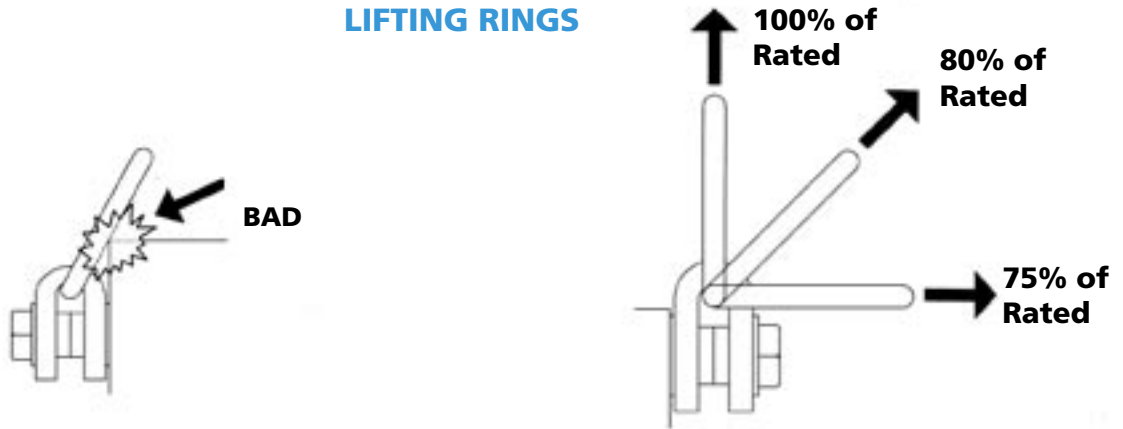

SIDE PULL HOIST RING

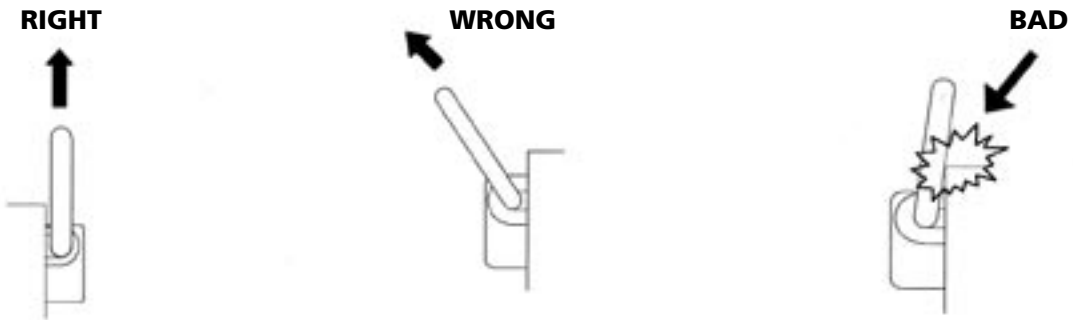

FORGED HOIST RING

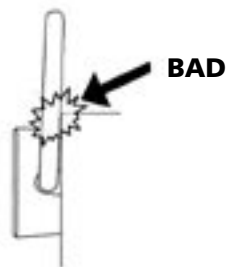

LARGE OPENING HOIST RING

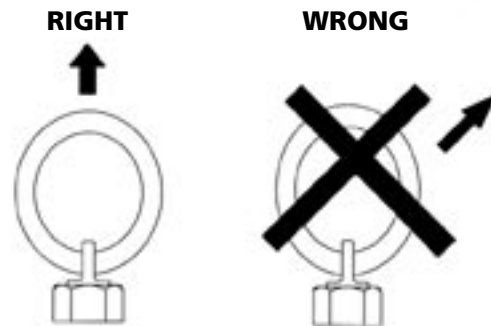

ROUND BASE SWIVEL & PIVOT HOIST RING

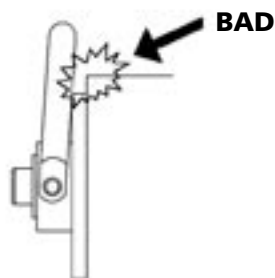

PIVOT LIFTING PLATE

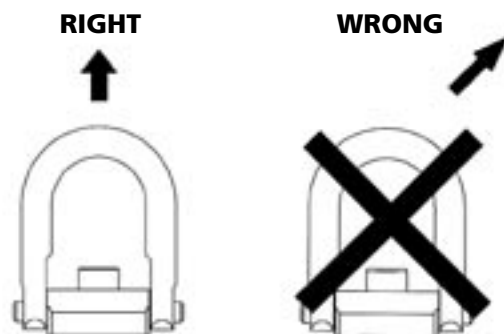

STREET PLATE LIFTING RING

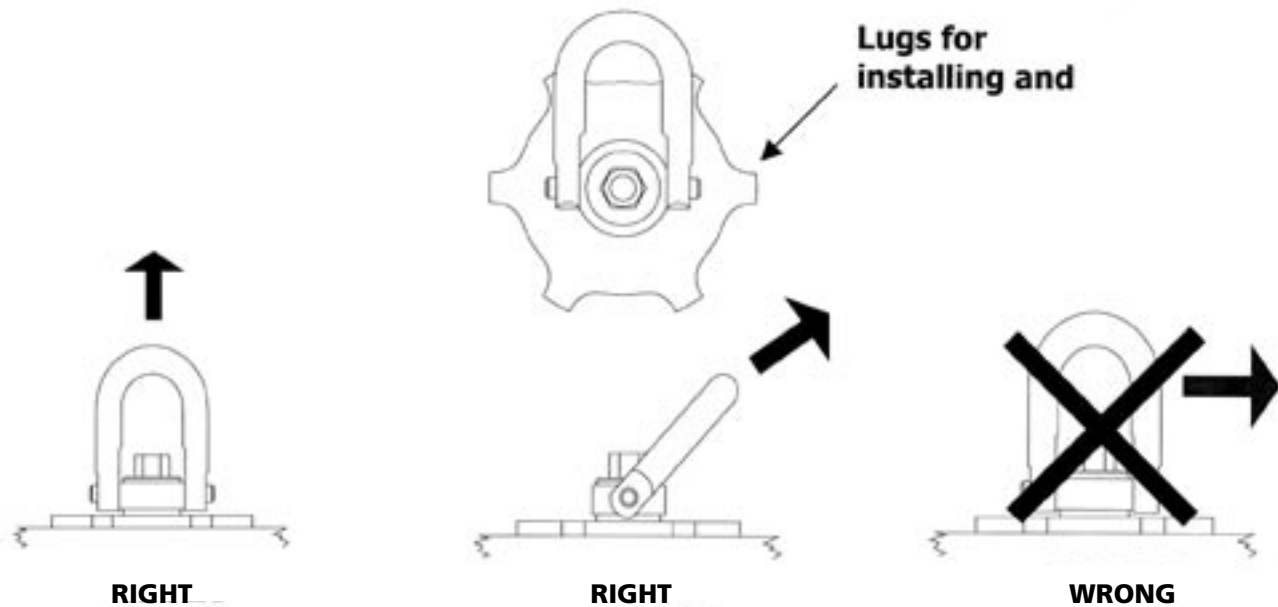

Welding Instruction

- Nut plate should have 1/8" clearance to trench plate
- It is allowable to replace an old nut if all previous weld metal is removed
- Use jig to make sure threaded plate is flush and square with top surface of trench plate
- Preheat plate to 450°-700°F
- Weld using Lincoln Jet Weld #ED010558 LH 70 - E7018 or 7024 - 3/16 dia. rod or equivalent
- Back-gouge root to sound metal
- Weld second side
- Grind weld on top surface flush
- Allow slow cooling

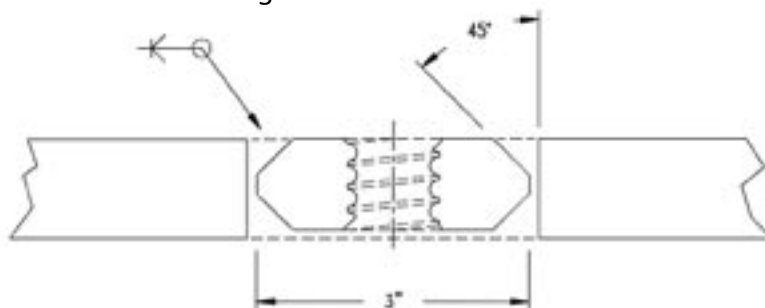

NOTE: After the nut has been welded to the plate, surfaces of the weld must be ground to the same surface level as the trench plate. This procedure allows the hoist ring to sit flush against the trench plate surface. Failure to do so will cause the hoist ring to sit improperly, and will lead to usage failure.

Material

- Threaded insert plate made from AISI 4140 steel, quench and tempered to Hardness Rockwell C 28-34
- Insert plate shall have minimum 1" thickness
- Shape can be square or round, 3" diameter

Lifting Device Safety information

TE-CO Hoist Rings are solely intended for use by trained, qualified, and experienced users. Misuse of any TE-CO Hoist Ring or lack of supervision and inspection can lead to serious accidents, and possibly death. TE-CO has always stressed that safety is of the utmost importance.

Prior to any use of TE-CO Hoist Rings, evaluation of the product application, safety precautions, safe working load, and control of all field conditions is mandatory. Prevent applications that exceed the safe working load or any other product misuse. TE-CO cautions you that all safety factors shown are approximate. **Safe working loads should never be exceeded under any circumstances.**

If you have questions about the proper use or installation of any TE-CO Hoist Ring, please contact our office directly.

109 Quinter Farm Road, Union, OH 45322 • (800) 543-4071

Safety Notes

TE-CO ensures that the materials used on all our Hoist Ring products meet or exceed the safety requirements for lifting. The safe working loads listed are based upon a new or "as new" condition product. A safe working load is considered to be the greatest load that should be applied to an item at any time.

Inspection and Maintenance

In order to insure the safest lifting, and all for safety purposes, TE-CO Hoist Rings must be properly used and maintained. Hoist rings are subject to wear, corrosion, deformation, overloading, and other limiting factors, which may affect the safe working load. Prior to use, any TE-CO Hoist Ring product should be regularly inspected to determine if it may be used, or whether it should be removed from service. It is the responsibility of the user to inspect all lifting units for signs of wear, and to discard any parts that show visible signs of wear. Every user should establish a routine safety inspection program for visual inspection of all products to determine whether signs of wear (e.g. cracks, corrosion, deformation) are present. The product inspection schedule should be established based upon factors such as frequency of use, period of use, and environment. **In addition to regular safety inspection, the following safety directives must be followed:**

- Prior to use, always inspect hoist rings for possible wear or damage.
- Never use hoist rings that show any sign of wear or damage.
- Never use hoist rings if bail is bent or elongated.
- Prior to use, threads must be clean, undamaged, and must fit properly.
- Always install hoist rings using the listed torque value. Periodically check torque, because screws could loosen during extended service.
- Bent bolts should be discarded or replaced – never straightened. Failure to do so may lead to serious injury or death.
- Never use washers or spacers between bushing and mounting surface.
- Always make sure the hoist ring pivots and rotates freely in all directions.
- Never use hoist rings near or around corrosive material.
- If hoist ring is exposed to extreme hot or cold temperatures, please contact our engineering department for suggestions or consultation.
- Safe working loads should never be exceeded under any circumstances.