

THE REQUIREMENTS FOR ACQUIRING THE PRODUCT(S) DESCRIBED HEREIN SHALL CONSIST OF THIS SPECIFICATION SHEET AND THE ISSUE OF THE FOLLOWING SPECIFICATION LISTED IN THAT ISSUE OF THE DOORSS SPECIFIED IN THE SOLICITATION: MIL-I-45914

THIS SPECIFICATION IS APPROVED FOR USE BY ALL DEPARTMENTS AND AGENCIES OF THE DEPARTMENT OF DEFENSE.

Form Approved  
OMB No. 0704-0188

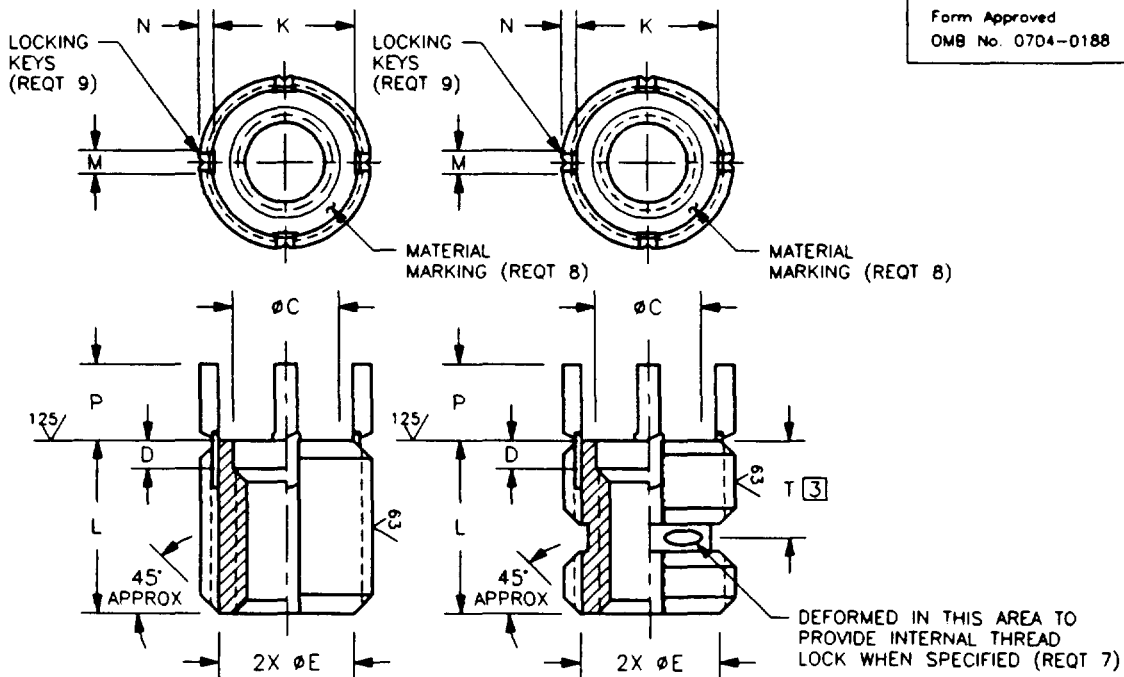

TABLE I. COARSE INTERNAL THREADS

DASH NO.	INTERNAL THREAD MIL-S-8879 UNJC-3B	EXTERNAL THREAD FED-STD-H28/2 EXCEPT MODIFIED MINOR DIA.		ØC	D	ØE	K	L	KEY DIMENSIONS			T
		SIZE	ØMINOR						M REF	N REF	P REF	
101	.190-24	.4375-14UNC-2A	.383 .375	.196	.070	.375	.344	.312	.068	.040	.130	.220
102	.250-20	.500-13UNC-2A	.440 .432	.257	.070	.430	.407	.375	.068	.040	.190	.220
103	.3125-18	.5625-12UNC-2A	.503 .495	.316	.070	.495	.469	.437	.068	.040	.190	.220
104	.375-16	.625-11UNC-2A	.565 .551	.380	.070	.550	.532	.500	.068	.040	.190	.250
105	.4375-14	.6875-11NS-2A	.625 .615	.445	.100	.615	.595	.625	.068	.040	.190	.280
106	.500-13	.8125-16UN-2A	.752 .744	.507	.100	.745	.720	.688	.068	.040	.190	.280
107	.5625-12	.875-14UNF-2A	.815 .807	.580	.100	.805	.782	.812	.068	.040	.190	.320
108	.625-11	1.000-12UNF-2A	.924 .916	.640	.100	.915	.850	.875	.103	.070	.250	.330
109	.750-10	1.250-12UNF-2A	1.175 1.165	.763	.100	1.165	1.100	1.125	.103	.070	.250	---
109L	.750-10	1.250-12UNF-2A	1.175 1.165	.763	.100	1.165	1.100	1.250	.103	.070	.250	.490
110	.875-9	1.375-12UNF-2A	1.300 1.290	.888	.100	1.290	1.225	1.250	.103	.070	.250	---
110L	.875-9	1.375-12UNF-2A	1.300 1.290	.888	.100	1.290	1.225	1.375	.103	.070	.250	.490
111	1.000-8	1.500-12UNF-2A	1.424 1.416	1.015	.100	1.415	1.350	1.375	.103	.070	.250	---
111L	1.000-8	1.500-12UNF-2A	1.424 1.416	1.015	.100	1.415	1.350	1.500	.103	.070	.250	.550

© ENTIRE STANDARD REVISED

INCH-POUND

PREPARING ACTMITY: ARMY-AR	MILITARY SPECIFICATION SHEET	SPECIFICATION SHEET NUMBER
CUSTODIANS: ARMY- AR NAVY- AS	TITLE	MS51832C 9 MAR 92
AIR FORCE- 99 DLA-	INSERT, SCREW-THREAD, LOCKED IN, KEY-LOCKED, EXTRA HEAVY DUTY	SUPERSEDING MS51832B 7 DEC 84
REVIEW: MI, AV, SH, 82, IS		AMSC- N/A FSC- 5340
USER: AT, EC, MC		
PROJECT NUMBER: 5340-2053		

DISTRIBUTION STATEMENT A Approved for public release; distribution is unlimited. Page 1 of 3

THE REQUIREMENTS FOR ACQUIRING THE PRODUCT(S) DESCRIBED HEREIN SHALL CONSIST OF THIS SPECIFICATION SHEET AND THE ISSUE OF THE FOLLOWING SPECIFICATION LISTED IN THAT ISSUE OF THE DOORS SPECIFIED IN THE SOLICITATION: MIL-I-45914

THIS SPECIFICATION IS APPROVED FOR USE BY ALL DEPARTMENTS AND AGENCIES OF THE DEPARTMENT OF DEFENSE.

Form Approved  
OMB No. 0704-0188

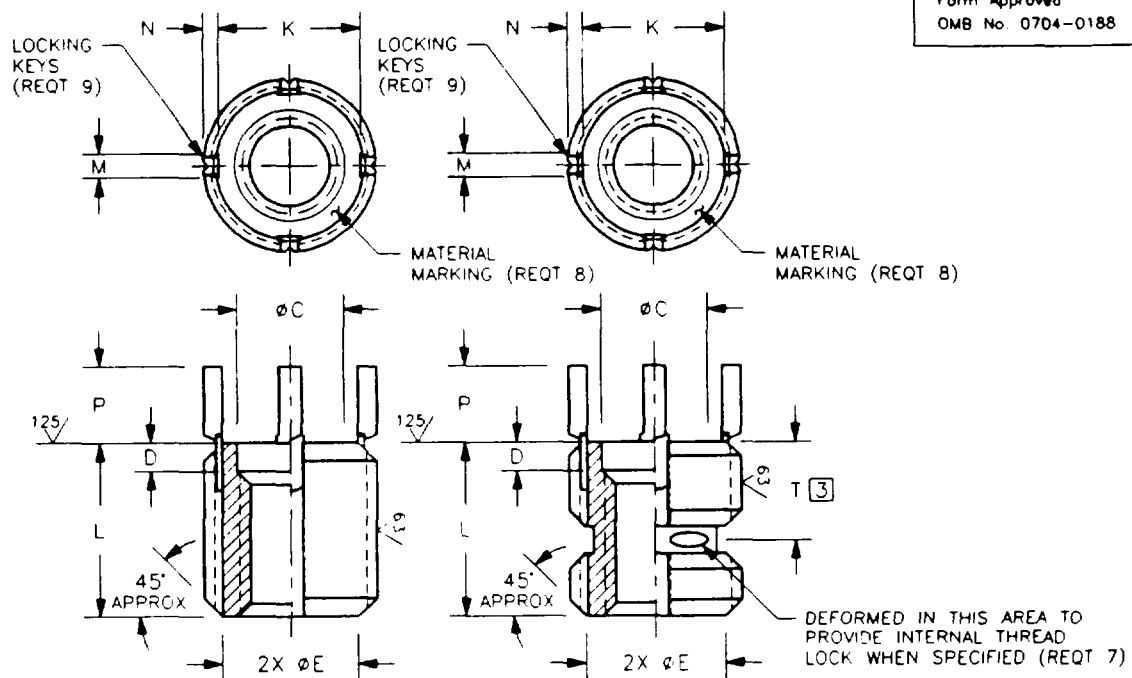

TABLE II FINE INTERNAL THREADS

DASH NO.	INTERNAL THREAD MIL-S-8879 UNJF-3B	EXTERNAL THREAD FED-STD-H28/2 EXCEPT MODIFIED MINOR DIA.		ØC	D	ØE	K	L	KEY DIMENSIONS			T
		SIZE	Ø MINOR						M REF	N REF	P REF	
201	.190-32	4375-14UNC-2A	383 375	±.005	±.010	REF	REF	±.015	.068	.040	.130	.220
202	.250-28	500-13UNC-2A	440 432	.257	.070	.430	.407	.375	.068	.040	.190	.220
203	.3125-24	5625-12UNC-2A	503 495	.316	.070	.495	.469	.437	.068	.040	.190	.220
204	.375-24	625-11UNC-2A	565 551	.380	.070	.550	.532	.500	.068	.040	.190	.250
205	.4375-20	6875-11NS-2A	625 615	.445	.100	.615	.595	.625	.068	.040	.190	.280
206	.500-20	8125-16UN-2A	752 744	.507	.100	.745	.720	.688	.068	.040	.190	.280
207	.5625-18	875-14UNF-2A	815 807	.580	.100	.805	.782	.812	.068	.040	.190	.320
208	.625-18	1.000-12UNF-2A	924 916	.640	.100	.915	.850	.875	.103	.070	.250	.330
209	.750-16	1.250-12UNF-2A	1.175 1.165	.763	.100	1.165	1.100	1.125	.103	.070	.250	---
209L	.750-16	1.250-12UNF-2A	1.175 1.165	.763	.100	1.165	1.100	1.250	.103	.070	.250	.490
210	.875-14	1.375-12UNF-2A	1.300 1.290	.888	.100	1.290	1.225	1.250	.103	.070	.250	---
210L	.875-14	1.375-12UNF-2A	1.300 1.290	.888	.100	1.290	1.225	1.375	.103	.070	.250	.490
211	1.000-12	1.500-12UNF-2A	1.424 1.416	1.015	.100	1.415	1.350	1.375	.103	.070	.250	---
211L	1.000-12	1.500-12UNF-2A	1.424 1.416	1.015	.100	1.415	1.350	1.500	.103	.070	.250	.550

PREPARING ACTIVITY: ARMY-AR  
CUSTODIANS: ARMY- AR NAVY- AS  
AIR FORCE- 99 DLA-  
REVIEW: MI, AV, SH, 82, IS  
USER: AT, EC, MC  
PROJECT NUMBER: 5340-2053

MILITARY SPECIFICATION SHEET  
TITLE  
INSERT, SCREW-THREAD,  
LOCKED IN, KEY-LOCKED,  
EXTRA HEAVY DUTY

SPECIFICATION SHEET NUMBER  
**MS51832C** 9 MAR 92  
SUPERSEDING  
MS51832B 7 DEC 84  
AMSC- N/A FSC- 5340

DISTRIBUTION STATEMENT A Approved for public release; distribution is unlimited. Page 2 of 3

THE REQUIREMENTS FOR ACQUIRING THE PRODUCT(S) DESCRIBED HEREIN SHALL CONSIST OF THIS SPECIFICATION SHEET AND THE ISSUE OF THE FOLLOWING SPECIFICATION LISTED IN THAT ISSUE OF THE DODISS SPECIFIED IN THE SOLICITATION: MIL-I-45914

THIS SPECIFICATION IS APPROVED FOR USE BY ALL DEPARTMENTS AND AGENCIES OF THE DEPARTMENT OF DEFENSE.

Form Approved  
OMB No. 0704-0188

**REQUIREMENTS:**

1. **MATERIAL:** STEEL, CORROSION-RESISTANT, TYPE 303 (UNS S30300) IN ACCORDANCE WITH AMS 5640 (TYPE 1) OR ASTM A 582, OR 303SE (UNS S30323) IN ACCORDANCE WITH AMS 5640 (TYPE 2), AMS 5738 OR ASTM A 582. STEEL, CORROSION-RESISTANT, TYPE A286 (UNS S66286) IN ACCORDANCE WITH AMS 5734 OR AMS 5737. STEEL, ALLOY, GRADE 4140 (UNS G41400) IN ACCORDANCE WITH MIL-S-5626 OR GRADE 8740 (UNS G87400) IN ACCORDANCE WITH AMS 6322. LOCKING KEYS: STEEL, CORROSION-RESISTANT, TYPE 302 CHEMICAL COMPOSITION OF ASTM A 580 ONLY.
2. **CADMIUM PLATING AND SURFACE TREATMENT:** CORROSION-RESISTANT STEEL SHALL BE PASSIVATED IN ACCORDANCE WITH QQ-P-35. ALLOY STEEL SHALL BE CADMIUM PLATED IN ACCORDANCE WITH QQ-P-416, TYPE II, CLASS 3. THE LOCKING KEYS MAY OR MAY NOT BE CADMIUM PLATED.
3. **LUBRICATION:** INSERTS WITH SELF-LOCKING INTERNAL THREADS SHALL BE DRY FILM LUBRICATED IN ACCORDANCE WITH MIL-L-46010, TYPE I. THE LOCKING KEYS MAY OR MAY NOT BE LUBRICATED.
4. **SURFACE TEXTURE:** MACHINED SURFACES SHALL BE IN ACCORDANCE WITH ANSI/ASME B46.1.
5. **HEAT TREATMENT:** ALLOY STEEL INSERTS SHALL BE HEAT TREATED TO 160,000 psi Ft<sub>u</sub> MINIMUM IN ACCORDANCE WITH MIL-H-6875. CORROSION-RESISTANT STEEL INSERTS, TYPE A286 (AMS 5734), SHALL BE HEAT TREATED TO 140,000 psi Ft<sub>u</sub> MINIMUM.
6. **HARDNESS:** ALLOY STEEL INSERTS SHALL HAVE A HARDNESS RANGE OF 36-40 HRC. CORROSION-RESISTANT STEEL INSERTS, TYPE A286, SHALL HAVE A HARDNESS RANGE OF 29-38 HRC.
7. **PART NUMBER:** THE PART NUMBER SHALL CONSIST OF THE BASIC MS SHEET NUMBER PLUS THE DASH NUMBER TAKEN FROM TABLE I OR TABLE II, AS APPLICABLE:  
 EXAMPLE: MSS1832 - 102 L  
 ADD "L" AS SUFFIX TO DASH NUMBER FOR INTERNAL THREAD LOCK. LEAVE BLANK IF INTERNAL THREAD LOCK IS NOT REQUIRED.  
 DASH NUMBER FROM TABLE I OR TABLE II.  
 MATERIAL: DASH INDICATES CRES, TYPE 303 OR 303SE. ADD "CA" IN LIEU OF DASH FOR CRES, TYPE A286. ADD "A" IN LIEU OF DASH FOR ALLOY STEEL, GRADE 4140 OR 8740.  
 BASIC MS SHEET NUMBER.  
 EXAMPLE: MSS1832CA102L INDICATES - INSERT, SCREW-THREAD, LOCKED IN, KEY-LOCKED, EXTRA HEAVY DUTY, CRES A286, .250-20UNC-3B INTERNAL THREAD WITH INTERNAL THREAD LOCK FEATURE.
8. **MATERIAL MARKING:** CRES 303 OR 303SE HAS NO IDENTIFYING MARK. CRES A286 SHALL BE IDENTIFIED ON TOP OF INSERT BY ONE (1) LINE OR DASH MARK. ALLOY STEEL 4140 OR 8740 SHALL BE IDENTIFIED ON TOP OF INSERT BY TWO (2) PARALLEL LINES OR DASH MARKS.
9. INSERTS WITH INTERNAL THREAD SIZE .250 AND SMALLER SHALL BE SUPPLIED WITH TWO (2) LOCKING KEYS SPACED 180° APART. INSERTS WITH INTERNAL THREAD SIZE .3125 AND GREATER SHALL BE SUPPLIED WITH FOUR (4) LOCKING KEYS SPACED 90° APART.
10. INSERTS SHALL BE FREE OF ALL HANGING BURRS AND SLIVERS WHICH MIGHT BECOME DISLODGED UNDER USAGE.
11. **SOURCE IDENTIFICATION MARK:** SOURCE IDENTIFICATION MARK SHALL BE IN ACCORDANCE WITH MIL-I-45914.
12. ALL DIMENSIONS ARE AFTER CADMIUM PLATING OR SURFACE TREATMENT AND PRIOR TO THE ADDITION OF THE LUBRICATION.
13. FILLETS ARE R.015 MAXIMUM.

**NOTES:**

1. ALL DIMENSIONS ARE IN INCHES.
2. INSTALLATION OF INSERTS SHALL BE IN ACCORDANCE WITH MS51835.
3. DISTANCE TO CENTER OF INTERNAL THREAD LOCK.
4. IN THE EVENT OF A CONFLICT BETWEEN THE TEXT OF THIS STANDARD AND THE REFERENCES CITED HEREIN, THE TEXT OF THIS STANDARD SHALL TAKE PRECEDENCE.
5. REFERENCED GOVERNMENT (OR NON-GOVERNMENT) DOCUMENTS OF THE ISSUE LISTED IN THAT ISSUE OF THE DEPARTMENT OF DEFENSE INDEX OF SPECIFICATIONS AND STANDARDS (DODISS) SPECIFIED IN THE SOLICITATION FORM A PART OF THIS STANDARD TO THE EXTENT SPECIFIED HEREIN.

PREPARING ACTIVITY: ARMY-AR	MILITARY SPECIFICATION SHEET	SPECIFICATION SHEET NUMBER
CUSTODIANS: ARMY- AR NAVY- AS	TITLE	MS51832C 9 MAR 92
AIR FORCE- 99 DLA-	INSERT, SCREW-THREAD, LOCKED IN, KEY-LOCKED, EXTRA HEAVY DUTY	SUPERSEDING MS51832B 7 DEC 84
REVIEW: MI, AV, SH, 82, IS		AMSC- N/A FSC- 5340
USER: AT, EC, MC		
PROJECT NUMBER: 5340-2053		

DISTRIBUTION STATEMENT A Approved for public release; distribution is unlimited. Page 3 of 3